

Directional valve 2-way/2-position

$Q_{\max} = 30 \text{ l/min}$, $p_{\max} = 250 \text{ bar}$

switching solenoid with emergency override, direct acting, poppet type

Type series: WS22GNZ5...



- Screw-in cartridge valve
- For cavity ALM
- All external parts with zinc-nickel plating according to DIN EN ISO 19598
- With bidirectional seat-valve shut-off
- Low head loss
- High flow rates
- Compact construction
- Installation in threaded port body type GALMA
- De-energized closed
- The slip-on coil can be rotated, and it can be replaced without opening the hydraulic envelope
- High pressure wet-armature solenoids
- Various plug-connector systems and voltages are available

Description

The 2-way/2-position solenoid-operated directional valves, series WS22..., are size 5, direct acting poppet type screw-in valves with an M20x1,5 mounting thread. They are designed on the poppet/seat principle, and are therefore virtually leak-free in both directions of flow (bidirectional seat-valve shut-off). All external parts of the screw-in valves are zinc-nickel plated, and are thus suitable for use in the harshest operating environments. The slip-on coils can be replaced without

opening the hydraulic envelope and can be positioned at any angle through 360°. These screw-in valves are predominantly used in certain mobile and industrial applications where leak-tight shut-off functions are crucially important. Examples are where loads, tensions, or clamping forces must be held without leakage. For self-assembly, please refer to the section related data sheets.

Symbol

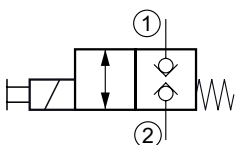

Technical data

General characteristics	Description, value, unit
Function group	Directional valve
Function	2-way/2-position
Design	Screw-in cartridge valve
Controls	switching solenoid with emergency override
Characteristic	direct acting, poppet type
Construction size	NG 5
Thread size	M20×1,5
Mounting attitude	unrestricted
Weight	0.35 kg
Cavity acc. factory standard	For cavity ALM
Tightening torque steel	50 Nm
Tightening torque aluminium	50 Nm
Tightening torque tolerance	± 10 %
Minimum ambient temperature	- 25 °C
Maximum ambient temperature	+ 50 °C
Surface protection	All external parts with zinc-nickel plating according to DIN EN ISO 19598
Sealing material	see ordering code
Seal kit order number	NBR: DS-245-N / FKM-DS-245-V

Hydraulic characteristics	Description, value, unit
Maximum operating pressure	250 bar
Maximum flow rate	30 l/min
Flow direction	see symbol
Hydraulic fluid	HL and HLP mineral oil according to DIN 51 524; other fluids on request!
Minimum fluid temperature	- 25 °C
Maximum fluid temperature	+ 80 °C
Viscosity range	10 ... 500 mm ² /s (cSt)
Recommended viscosity range	15 ... 250 mm ² /s (cSt)
Minimum fluid cleanliness (cleanliness class according to ISO 4406:1999)	class 20/18/15

Electric characteristics	Description, value, unit
Actuator type	solenoid coil
Solenoid coils type	D36
Supply voltage DC	12/24 V DC
Supply voltage AC	115/230 (50 ... 60 Hz) V AC
Supply voltage tolerance	± 10 %
Maximum permissible power consumption	VAC: 25, VDC: 27 W
Switching time	30...120 ms (energizing), 20...50 ms (de-energized)
Relative duty cycle	100 %
Electrical connection coil	several connection types available, see ordering code
Protection class solenoid coil to ISO 20 653 / EN 60 529	IP 65 / IP 67 / IP 69K, see "Ordering code" (with appropriate mating connector and proper fitting and sealing)



NOTE!

The switching time can be strongly influenced by flow rate, pressure, viscosity, and the dwell period under pressure. In practice, the switching time may therefore deviate from the specified value range.

Performance graphs

measured with oil viscosity 33.0 mm²/s (cSt), coil at steady-state temperature and 10 % undervoltage

$p = f(Q)$ Performance limit

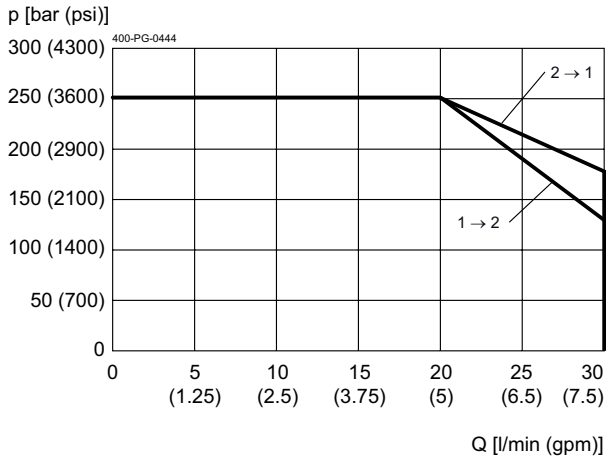

$\Delta p = f(Q)$ Pressure drop-flow rate characteristic

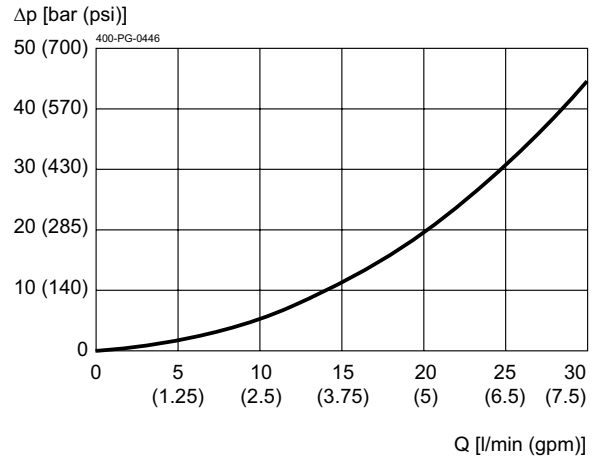

Dimensions and sectional view

Beispiel für die Masseinheit:
Example for the dimensional units:
 0.79 = 0.79 mm millimeter
 (.031) = 0.031" inch

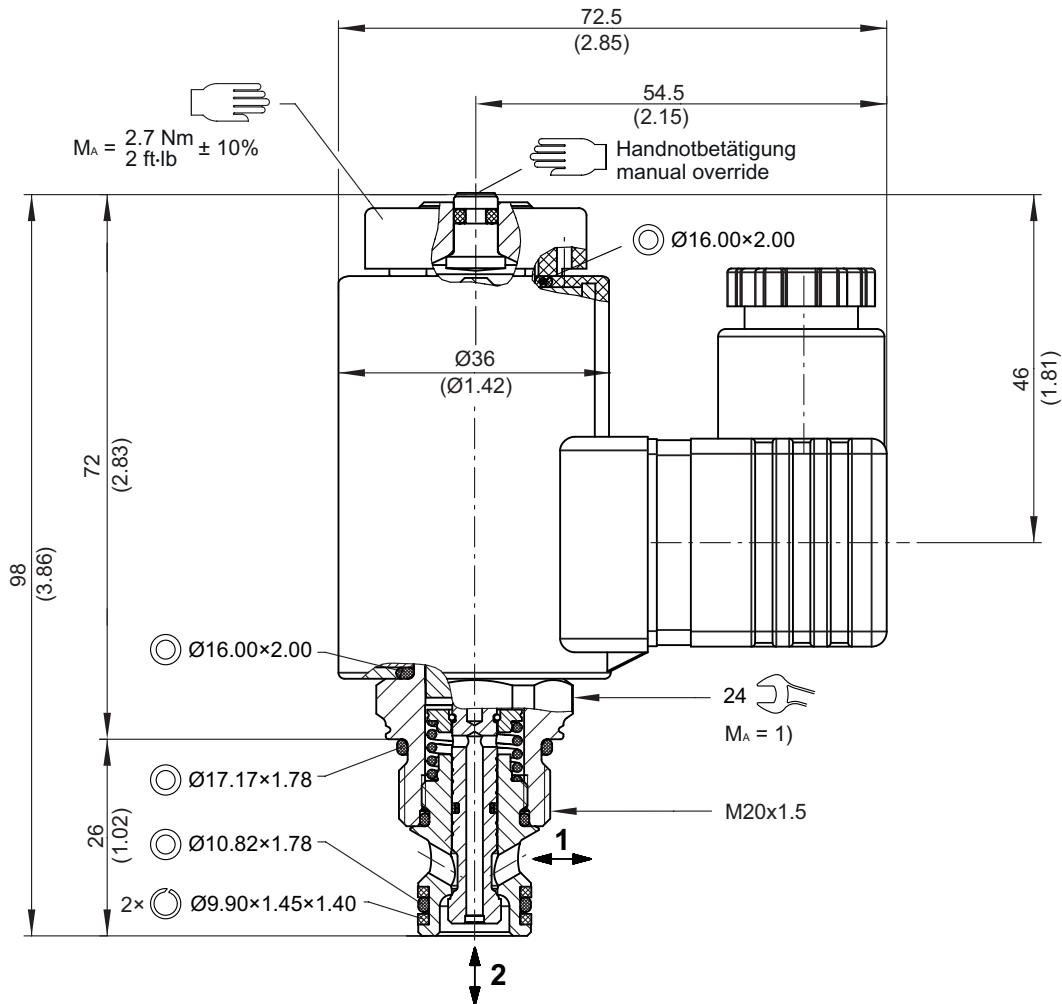

Installation information



ATTENTION!

Only qualified personnel with mechanical skills may carry out any maintenance work. Generally, the only work that should ever be undertaken is to check, and possibly replace, the seals. When changing seals, oil or grease the new seals thoroughly before fitting them.



IMPORTANT!

1) When fitting the screw-in cartridge valve, use the specified tightening torque. The value can be found in the chapter "Technical data".

Ordering code

Ex.

W	S	22G	N	Z	5	_	-	4		24	D	_
---	---	-----	---	---	---	---	---	---	--	----	---	---

- W = seat valve, direct acting
- S = check valve function, seated design, two stage
- 22G = 2/2 function, de-energized closed
- N = electrically operated, V DC = 27 W / V AC = 25 W
- Z = special features - with thread M20x1,5
- 5 = nominal size 5
- (blank) = NBR (nitril-butadien-rubber / BUNA) seals **(standard)**
- V = FKM (fluorocarbon rubber / VITON) seals
(special seals - please contact BUCHER)
- 1 ... 9 = design stage (omit when ordering new units)
- ... = voltage e.g. 24 (24 V)
- D = current DC
- A = current AC
- (blank) = DIN EN 175301-803 connection, 3-pole 2 P+E with mating plug, IP 65 **(standard)**
- M100 = DIN EN 175301-803 connection, 3-pole 2 P+E
- C = Kostal plug connection (IP 65)
- JT = Junior Timer radial plug connection (with protection diode, IP65)
- IT = Junior Timer axial plug connection (with protection diode, IP65)
- D = Deutsch plug connection 45° DT04-2P (IP 67/69K)
- DT = Deutsch plug connection 45° DT04-2P (with protection diode, IP 67/69K)
- S = AMP Superseal 1.5 (IP67) / Metri-Pack 150 (IP65) plug connection
- F = flying leads (500 mm)

} mating plug not supplied

Related data sheets

Reference	Description
400-P-040011	Form tools
400-P-120110	Solenoid coil D36
400-P-040201	Cavity ALM
400-P-720105	Threaded port body GALMA