

# Directional valve 2-way/2-position

$Q_{\max} = 180 \text{ l/min}$ ,  $p_{\max} = 350 \text{ bar}$

switching solenoid, pilot operated, poppet type

Type series: WRVP22G-12A-\_B...

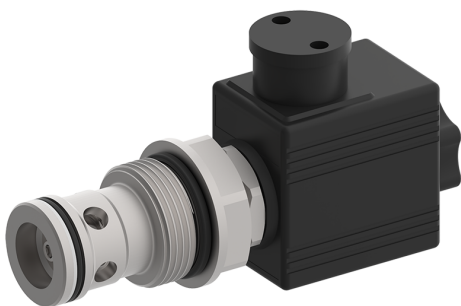

- Screw-in cartridge valve
- For cavity LA/C1620
- All external parts with zinc-nickel plating according to DIN EN ISO 19598
- Fits common cavity according to ISO and NFPA
- Reliable switching, even after long dwell times
- Low head loss
- High flow rates
- Installation in threaded port body type GLA-11
- The slip-on coil can be rotated, and it can be replaced without opening the hydraulic envelope
- High pressure wet-armature solenoids
- Various plug-connector systems and voltages are available

## Description

The 2-way/2-position solenoid operated directional seat valves, series WRVP22G..., are size NG 12 / SAE 16, two stage, pressure balanced screw-in valves with a 1 5/16-12 UN mounting thread. They are designed on the poppet/seat principle, and the 2 to 1 flow path is therefore virtually leak-free. "De-energized closed" function is available. The straightforward design delivers a good price/performance ratio and outstanding headloss/flow ratings. These valves are used in mobile and industrial applications where leak-tight shutoff

functions are crucially important. Examples are where loads, tensions, or clamping forces must be held without leakage. All external parts of the screw-in valve are zinc-nickel plated and are thus suitable for use in the harshest operating environments. The slip-on coils can be replaced without opening the hydraulic envelope and can be positioned at any angle through 360°. For self-assembly, please refer to the section related data sheets.

## Symbol

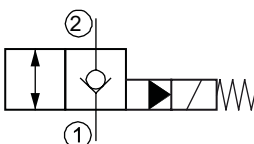

## Technical data

General characteristics	Description, value, unit
Function group	Directional valve
Function	2-way/2-position
Design	Screw-in cartridge valve
Controls	switching solenoid
Characteristic	pilot operated, poppet type
MTTFd value	150 years
Construction size	NG 12 / SAE 16
Thread size	1 5/16-12 UN-2A
Mounting attitude	unrestricted
Weight	1.70 kg
Cavity acc. ISO	fits into ISO 17209: 1 5/16-01-0-13
Cavity acc. NFPA	fits into NFPA/T3.5.50: 1.312-01-0-09
Cavity acc. factory standard	For cavity LA/C1620
Tightening torque steel	245 Nm
Tightening torque aluminium	245 Nm
Tightening torque tolerance	± 10 %
Minimum ambient temperature	- 25 °C
Maximum ambient temperature	+ 50 °C
Surface protection	All external parts with zinc-nickel plating according to DIN EN ISO 19598
Sealing material	see ordering code
Seal kit order number	NBR: DS-499-N / FKM: DS-499-V

Hydraulic characteristics	Description, value, unit
Maximum operating pressure	350 bar
Maximum flow rate	180 l/min
Flow direction	see symbol
Hydraulic fluid	HL and HLP mineral oil according to DIN 51 524; other fluids on request!
Minimum fluid temperature	- 25 °C
Maximum fluid temperature	+ 80 °C
Viscosity range	10 ... 500 mm <sup>2</sup> /s (cSt)
Recommended viscosity range	15 ... 250 mm <sup>2</sup> /s (cSt)
Minimum fluid cleanliness (cleanliness class according to ISO 4406:1999)	class 20/18/15

Electric characteristics	Description, value, unit
Actuator type	solenoid coil
Solenoid coils type	36X48/16.1
Supply voltage DC	12/24 V DC
Supply voltage tolerance	± 10 %
Maximum permissible power consumption	19 W
Switching time	Switching time measured at: U <sub>N</sub> ; Δp = 300 bar; Q = 120 l/min; T <sub>Ambient</sub> = 20 °C; ϑ = 46 mm <sup>2</sup> /s 36 ms (energizing) 100 ms (de-energizing)
Relative duty cycle	100 %
Electrical connection coil	several connection types available, see ordering code
Protection class solenoid coil to ISO 20 653 / EN 60 529	several classes of protection available, see ordering code (with appropriate mating connector and proper fitting and sealing)

## Performance graphs

measured with oil viscosity 33.0 mm<sup>2</sup>/s (cSt), coil at steady-state temperature and 10 % undervoltage

Δp = f (Q) Pressure drop-flow rate characteristic

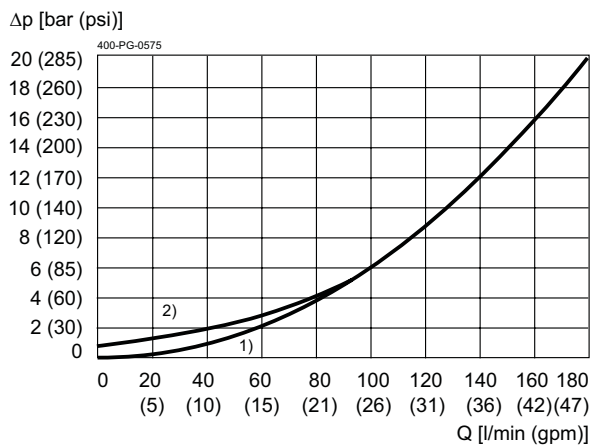

p = f (Q) Performance limit

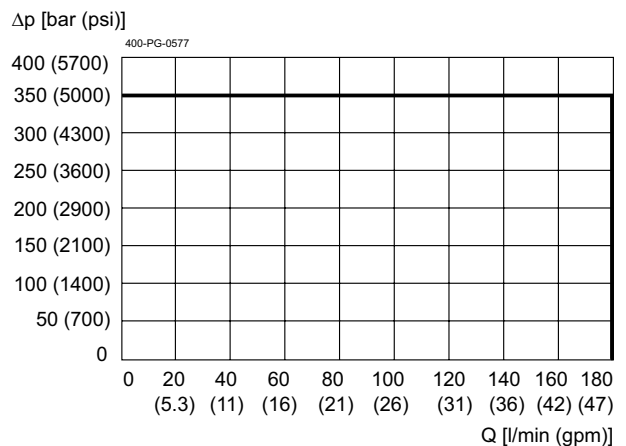

Dimensions and sectional view

Beispiel für die Masseinheit:  
Example for the dimensional units:

.031 = 0.031" inch  
(0.79) = 0.79 mm millimeter

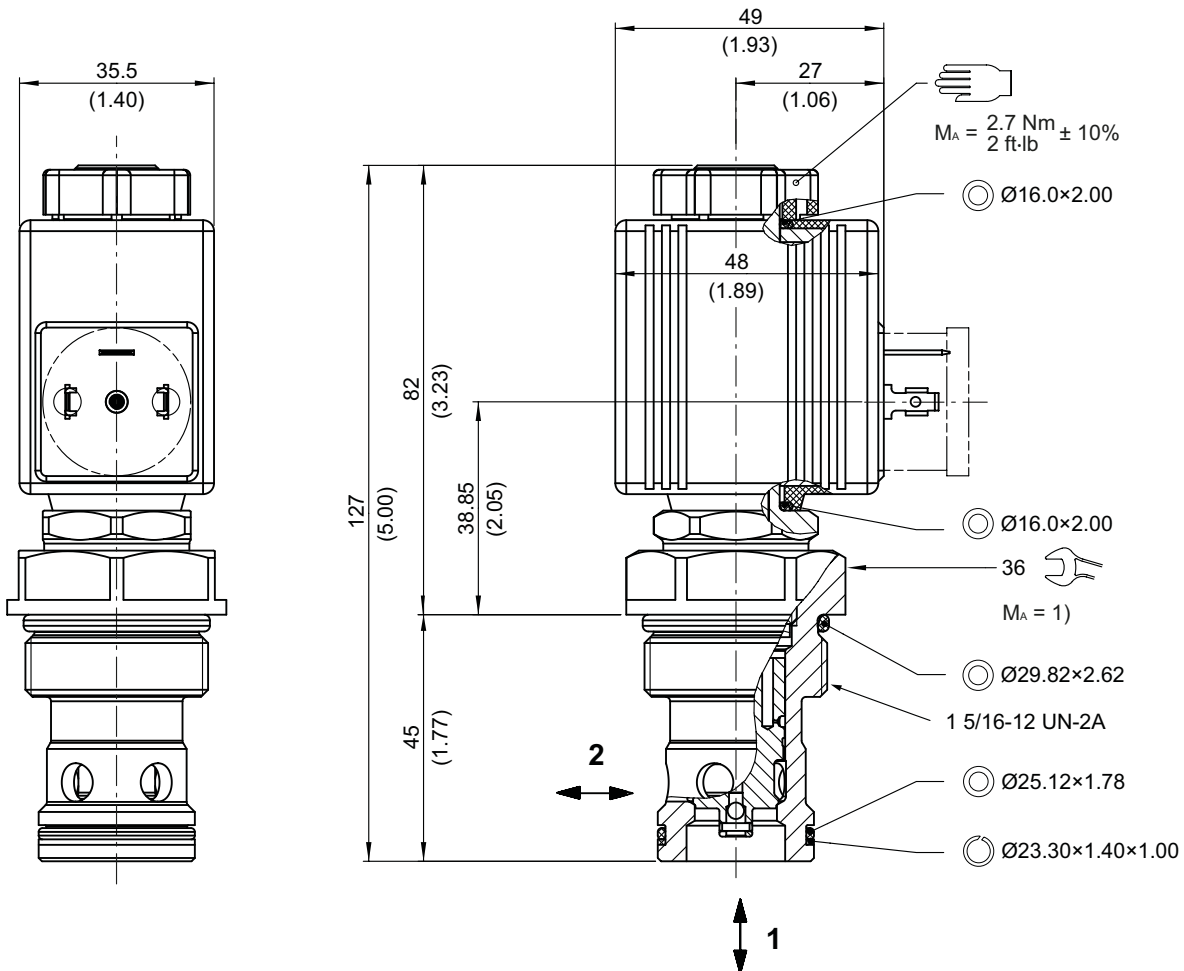

Installation information



**NOTE!**

1) When fitting the screw-in cartridge valve, use the specified tightening torque. The value can be found in the chapter "Technical data".



**ATTENTION!**

Only qualified personnel with mechanical skills may carry out any maintenance work. Generally, the only work that should ever be undertaken is to check, and possibly replace, the seals. When changing seals, oil or grease the new seals thoroughly before fitting them.

## Ordering code

Ex. 

W	R	V	P	22G	-	12	A	-	F	-	N	B	1	-	24	D	G	-
---	---	---	---	-----	---	----	---	---	---	---	---	---	---	---	----	---	---	---

- W = directional valve
- R = check valve function (seat-type)
- V = pilot operated
- P = electrically operated, V DC = 19 W
- 22G = 2-way/2-position, normally closed
- 12 = nominal size 12 / SAE 16
- A = cavity type LA/C1620
- F = main spool overlap (fine control)
- N = NBR (nitril-butadien-rubber / BUNA) seals **(standard)**
- V = FKM (fluorocarbon rubber / VITON) seals  
*(special seals - please consult BUCHER)*
- A ... Q = standard model according to valid data sheet
- Z ... R = special model after consultation
- 1 ... 9 = technical design no. (omit when ordering)
- ... = voltage e.g. 24 (24 V)
- D = current DC
- G = standard plug connection to DIN EN (3-pole, 2 P+E, IP 65)
- J = Junior Timer radial plug connection (IP 65)
- JR = Junior Timer radial plug connection (with protection diode, IP 65)
- U = Deutsch plug connection radial DT04-2P (IP 67/69K)
- UR = Deutsch plug connection radial DT04-2P (with protection diode, IP 67/69K)
- (blank) = without mating plug
- Q = with mating plug (only by connection type "G" possible)

## Related data sheets

Reference	Description
400-P-040011	Form tools
400-P-120212	Solenoid coil 36X48/16.1
400-P-067101	Cavity LA/C1620
400-P-742101	Threaded port body GLA-11...
400-P-010101	MTTFD Values for Hydraulic Valves

info.ch@bucherhydraulics.com

www.bucherhydraulics.com

© 2023 by Bucher Hydraulics AG Frutigen, 3714 Frutigen, Switzerland

All rights reserved.

Data is provided for the purpose of product description only, and must not be construed as warranted characteristics in the legal sense. The information does not relieve users from the duty of conducting their own evaluations and tests. Because the products are subject to continual improvement, we reserve the right to amend the product specifications contained in this catalogue.