

Directional valve 2-way/2-position

$Q_{\max} = 40 \text{ l/min}$, $p_{\max} = 350 \text{ bar}$

pilot operated, poppet type, switching solenoid with emergency override

Type series: WR22O_Z5-...



- Screw-in cartridge valve
- For cavity ALM
- All external parts with zinc-nickel coating according to DIN EN ISO 19598
- Installation in threaded port body type GALMA
- The slip-on coil can be rotated, and it can be replaced without opening the hydraulic envelope
- High pressure wet-armature solenoids
- Various plug-connector systems and voltages are available
- Seat tight shut-off
- Compact construction
- High flow rates
- Low head loss
- Reliable switching, even after long dwell times
- With manual override

Description

The 2-way/2-position solenoid-operated directional seat valves, series WR22_Z..., are size 5, two stage, pressure balanced screw-in valves with an M20x1,5 mounting thread. The main and pilot stages are both designed on the poppet/seat principle, and the 1 to 2 flow path is therefore virtually leak-free. The straight-forward design delivers a good price/performance ratio and outstanding head loss/ flow ratings. All external parts of the screw-in valves are zinc-nickel plated, and are thus suitable for use in the harshest opera-

ting environments. The slip-on coils can be replaced without opening the hydraulic envelope and can be positioned at any angle through 360°. These valves are primarily used as pilot valves in certain mobile and industrial applications where leak-tight shut-off functions are crucially important. Examples are where loads, tensions, or clamping forces must be held without leakage. For self-assembly, please refer to the section related data sheets.

Symbol

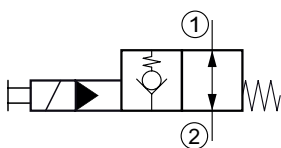

Technical Data

| General Characteristics | Description, value, unit |
|------------------------------|---|
| Function group | Directional valve |
| Function | 2-way/2-position |
| Design | Screw-in cartridge valve |
| Controls | switching solenoid with emergency override |
| Characteristic | pilot operated, poppet type |
| Construction size | nominal size 5 |
| Thread size | M20×1,5 |
| Mounting attitude | unrestricted |
| Weight | 0.40 kg |
| Cavity acc. factory standard | For cavity ALM |
| Tightening torque steel | 50 Nm |
| Tightening torque aluminium | 50 Nm |
| Tightening torque tolerance | ± 10 % |
| Minimum ambient temperature | - 25 °C |
| Maximum ambient temperature | + 50 °C |
| Surface protection | All external parts with zinc-nickel coating according to DIN EN ISO 19598 |
| Available seal types | several seal types available, see ordering code |
| Seal kit order number | NBR: DS-245-N / FKM: DS-245-V |

| Hydraulic Characteristics | Description, value, unit |
|--|--|
| Maximum operating pressure | 350 bar |
| Maximum flow rate | 40 l/min |
| Flow direction | see symbol |
| Hydraulic fluid | HL and HLP mineral oil according to DIN 51 524; other fluids on request! |
| Minimum fluid temperature | - 25 °C |
| Maximum fluid temperature | + 80 °C |
| Viscosity range | 10 ... 500 mm ² /s (cSt) |
| Recommended viscosity range | 15 ... 250 mm ² /s (cSt) |
| Minimum fluid cleanliness (cleanliness class according to ISO 4406:1999) | class 20/18/15 |

NOTE!

The switching safety of the valve is achieved by the volume flow and pressure drop (Δp).

| Electric Characteristics | Description, value, unit |
|--|--|
| Actuator type | solenoid coil |
| Solenoid coils type | D36 |
| Supply voltage DC | 12/24 V DC |
| Supply voltage AC | 115/230 V AC (50 ... 60 Hz) |
| Supply voltage tolerance | ± 10 % |
| Maximum permissible power consumption | Version "E": V DC = 17 W / V AC = 17 W Version "N": V DC = 27 W / V AC = 25 W |
| Switching time | Version "E": 35...105 ms (energized) / 20...70 ms (de-energized) Version "N": 25...135 ms (energized) / 20...40 ms (de-energized) |
| Relative duty cycle | 100 % |
| Electrical connection coil | several connection types available, see ordering code |
| Protection class solenoid coil to ISO 20 653 / EN 60 529 | several classes of protection available, see ordering code (with appropriate mating connector and proper fitting and sealing) |



NOTE!

The switching time can be strongly dependent on flow rate, pressure, oil viscosity and the dwell time under pressure. In practice, the switching time may therefore deviate from the specified value range.

Performance graphs

measured with oil viscosity 33.0 mm²/s (cSt), coil at steady-state temperature and 10 % undervoltage

$p = f(Q)$ Performance limit

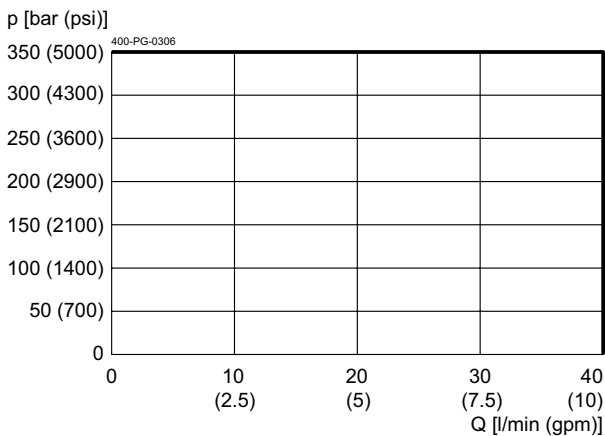

$\Delta p = f(Q)$ Pressure drop-flow rate characteristic

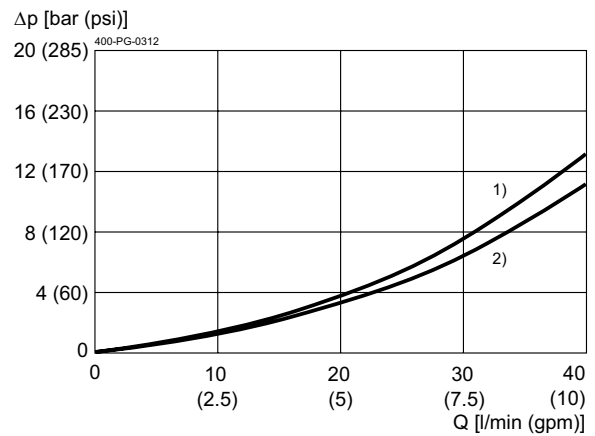

Version "E" - 17 W / Version "N" - 27/25 W
 1) 2 → 1, solenoid de-energized
 2) 1 → 2, solenoid de-energized

Dimensions and sectional view

Beispiel für die Masseinheit:
Example for the dimensional units:
0.79 = 0.79 mm millimeter
(.031) = 0.031" inch

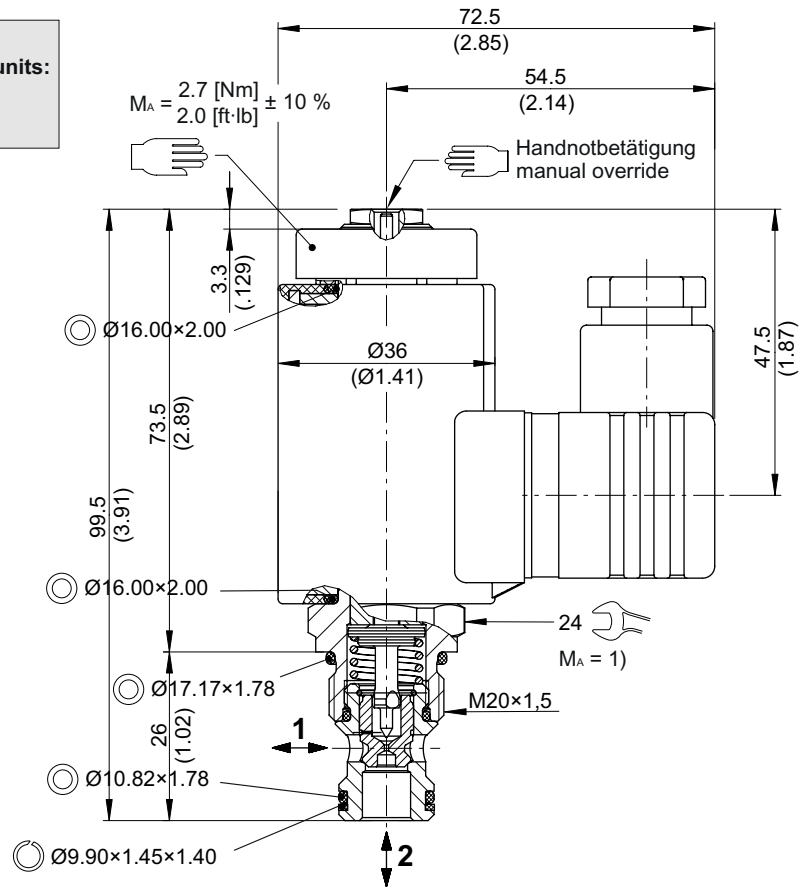

Installation information

i NOTE!
1) When fitting the screw-in cartridge valve, use the specified tightening torque. The value can be found in the chapter "technical data".

i NOTE!
The seals are not available individually. The seal kit order number can be found in the chapter "Technical data".

! ATTENTION!
Only qualified personnel with mechanical skills may carry out any maintenance work. Generally, the only work that should ever be undertaken is to check, and possibly replace, the seals. When changing seals, oil or grease the new seals thoroughly before fitting them.

Ordering code

Ex.

| | | | | | | | | | | | | |
|---|---|-----|---|---|---|---|---|---|--|----|---|---|
| W | R | 22O | E | Z | 5 | _ | - | 5 | | 24 | D | _ |
|---|---|-----|---|---|---|---|---|---|--|----|---|---|

- W = directional valve
 - R = check valve function, pilot operated
 - 22O = 2-way/2-position, normally open
 - E = electrically operated, V DC = 17 W / V AC = 17 W (standard)
 - N = electrically operated, V DC = 27 W / V AC = 25 W
 - Z = thread size M20×1,5 for cavity ALM
 - 5 = nominal size 5
 - (blank) = NBR (nitril-butadien-rubber / BUNA) seals (standard)
 - V = FKM (fluorocarbon rubber / VITON) seals (special seals - please consult BUCHER)
 - 1 ... 9 = technical design no. (omit when ordering)
 - ... = voltage e.g. 24 (24 V)
 - D = current DC
 - A = current AC
 - (blank) = DIN EN 175301-803 connection, 3-pole 2 P+E with mating plug (IP 65) (standard)
 - M100 = DIN EN 175301-803 connection, 3-pole 2 P+E
 - C = Kostal plug connection (IP 65)
 - JT = Junior Timer radial plug connection (with protection diode, IP 65)
 - IT = Junior Timer axial plug connection (with protection diode, IP 65)
 - D = Deutsch plug connection 45° DT04-2P (IP 67/69K)
 - DT = Deutsch plug connection 45° DT04-2P (with protection diode, IP 67/69K)
 - S = AMP Superseal 1.5 (IP 67) / Metri-Pack 150 (IP 65) plug connection
 - F = flying leads (500 mm)
- mating plug not supplied

Related data sheets

| Reference | Description |
|--------------|--------------------------|
| 400-P-040011 | Forming tools |
| 400-P-040201 | Cavity ALM |
| 400-P-720105 | Threaded port body GALMA |
| 400-P-120110 | Solenoid coil D36 |