

# Directional valve 2-way/2-position

$Q_{\max} = 140 \text{ l/min}$ ,  $p_{\max} = 350 \text{ bar}$

pilot operated, poppet type, switching solenoid

Type series: WR22G\_CA-10...



- Screw-in cartridge valve
- For cavity DC
- All external parts with zinc-nickel coating according to DIN EN ISO 19598
- Installation in threaded port body type DC-12
- The slip-on coil can be rotated, and it can be replaced without opening the hydraulic envelope
- High pressure wet-armature solenoids
- Various plug-connector systems and voltages are available
- Seat tight shut-off
- No external pilot drain required
- High flow rates
- Low head loss
- Reliable switching, even after long dwell times
- Also available as stack valve

## Description

The 2-way/2-position solenoid operated spool valves, series WR22\_C... are size 10, two stage, screw-in valves with an M24x1.5 mounting thread. The main stage as well as the pilot stage are designed on the proven poppet seat design, which ensures that the cartridges are leak-tight from B to A. The straightforward design delivers an outstanding price/performance ratio and good pressure loss/volume flow ratings. All external parts of the screw-in valves are zinc-nickel plated and

are thus suitable for use in the harshest operating environments. The slip-on coils can be replaced without opening the hydraulic envelope and can be positioned at any angle through 360°. These valves are used in mobile and industrial applications where leak-tight shutoff functions are crucially important. Examples are where loads, tensions, or clamping forces must be held without leakage. For self-assembly, please refer to the section related data sheets.

## Symbol

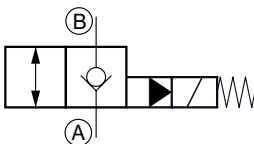

## Technical Data

General Characteristics	Description, value, unit
Function group	Directional valve
Function	2-way/2-position
Design	Screw-in cartridge valve
Controls	switching solenoid
Characteristic	pilot operated, poppet type
Construction size	nominal size 10
Thread size	M24×1,5
Mounting attitude	unrestricted
Weight	0.50 kg
Cavity acc. factory standard	For cavity DC
Tightening torque steel	100 Nm
Tightening torque aluminium	100 Nm
Tightening torque tolerance	± 10 %
Minimum ambient temperature	- 25 °C
Maximum ambient temperature	+ 50 °C
Surface protection	All external parts with zinc-nickel coating according to DIN EN ISO 19598
Available seal types	several seal types available, see ordering code
Seal kit order number	NBR: DS-276-N / FKM: DS-276-V

Hydraulic Characteristics	Description, value, unit
Maximum operating pressure	350 bar
Maximum flow rate	140 l/min
Flow direction	see symbol
Hydraulic fluid	HL and HLP mineral oil according to DIN 51 524; other fluids on request!
Minimum fluid temperature	- 25 °C
Maximum fluid temperature	+ 80 °C
Viscosity range	10 ... 500 mm <sup>2</sup> /s (cSt)
Recommended viscosity range	15 ... 250 mm <sup>2</sup> /s (cSt)
Minimum fluid cleanliness (cleanliness class according to ISO 4406:1999)	class 20/18/15

**NOTE!**

The switching safety of the valve is achieved by the volume flow and pressure drop ( $\Delta p$ ).

Electric Characteristics	Description, value, unit
Actuator type	solenoid coil
Solenoid coils type	D36
Supply voltage DC	12/24 V DC
Supply voltage AC	115/230 V AC (50 ... 60 Hz)
Supply voltage tolerance	± 10 %
Maximum permissible power consumption	Version "E": V DC = 17 W / V AC = 17 W Version "N": V DC = 27 W / V AC = 25 W
Switching time	Version "E": 50...150 ms (energized) / 15...40 ms (de-energized) Version "N": 40...195 ms (energized) / 20...40 ms (de-energized)
Relative duty cycle	100 %
Electrical connection coil	several connection types available, see ordering code
Protection class solenoid coil to ISO 20 653 / EN 60 529	several classes of protection available, see ordering code (with appropriate mating connector and proper fitting and sealing)



**NOTE!**

The switching time can be strongly dependent on flow rate, pressure, oil viscosity and the dwell time under pressure. In practice, the switching time may therefore deviate from the specified value range.

**Performance graphs**

measured with oil viscosity 33.0 mm<sup>2</sup>/s (cSt), coil at steady-state temperature and 10 % undervoltage

$p = f(Q)$  Performance limit

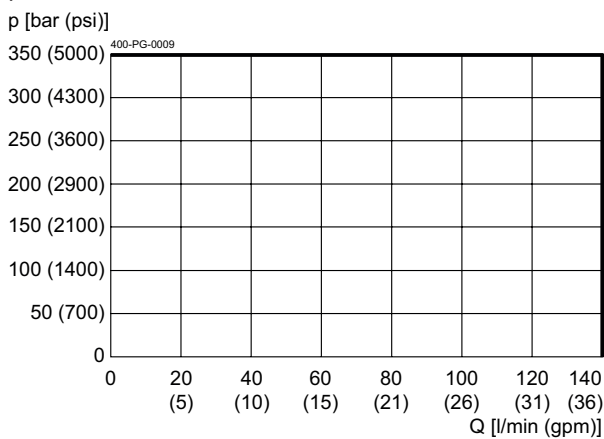

$\Delta p = f(Q)$  Pressure drop-flow rate characteristic

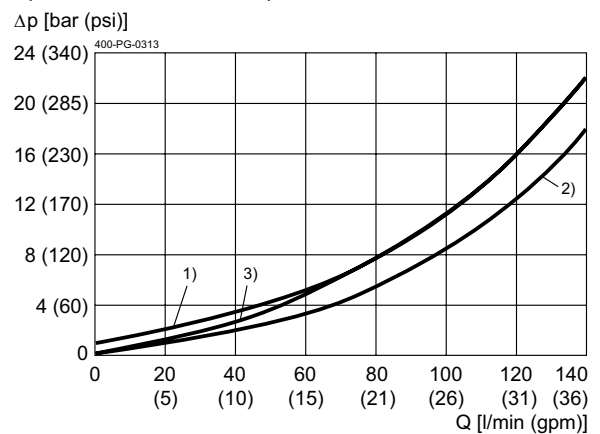

- 1) A → B, solenoid de-energizing
- 2) B → A, solenoid energizing
- 3) A → B, solenoid energizing

## Dimensions and sectional view

**Beispiel für die Masseinheit:**  
**Example for the dimensional units:**  
 0.79 = 0.79 mm millimeter  
 (.031) = 0.031" inch

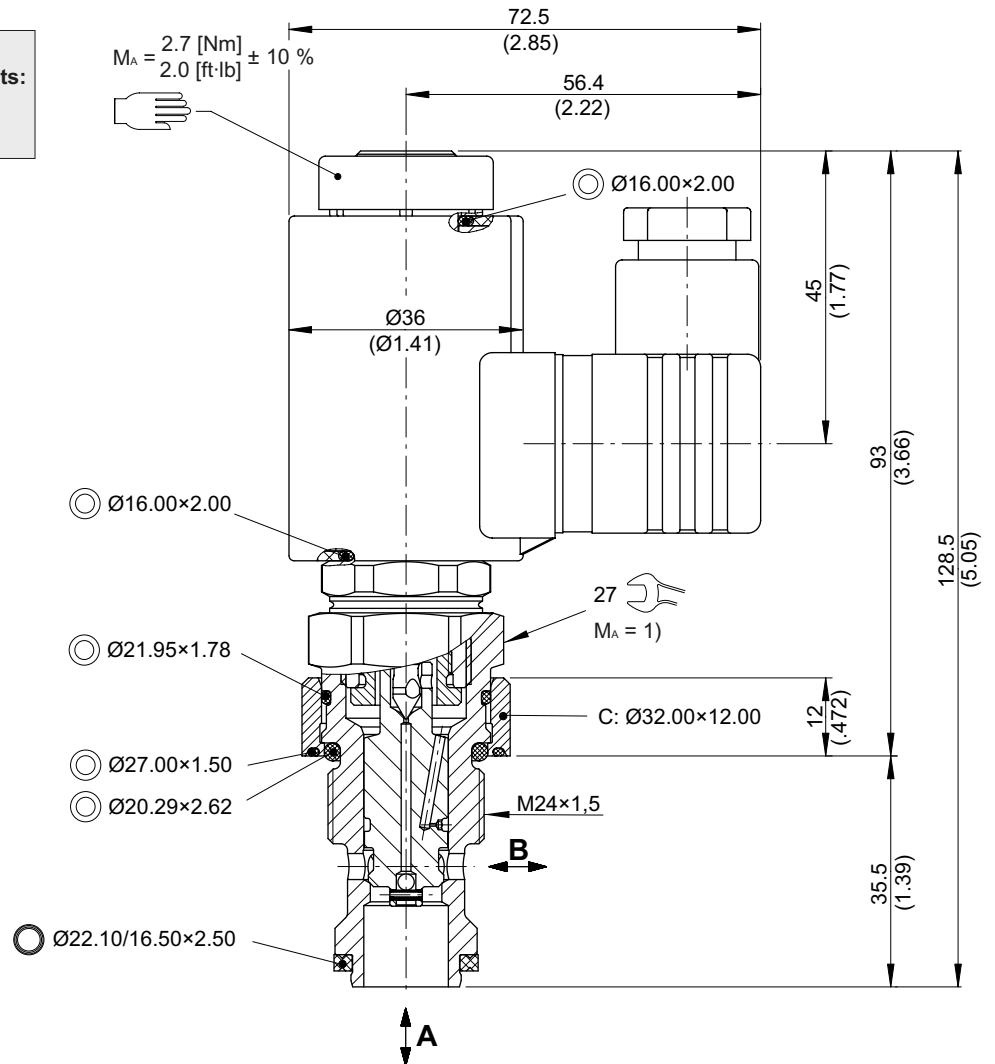

## Installation information

**i NOTE!**  
 1) When fitting the screw-in cartridge valve, use the specified tightening torque. The value can be found in the chapter "technical data".

**i NOTE!**  
 The seals are not available individually. The seal kit order number can be found in the chapter "Technical data".

**! ATTENTION!**  
 Only qualified personnel with mechanical skills may carry out any maintenance work. Generally, the only work that should ever be undertaken is to check, and possibly replace, the seals. When changing seals, oil or grease the new seals thoroughly before fitting them.

## Ordering code

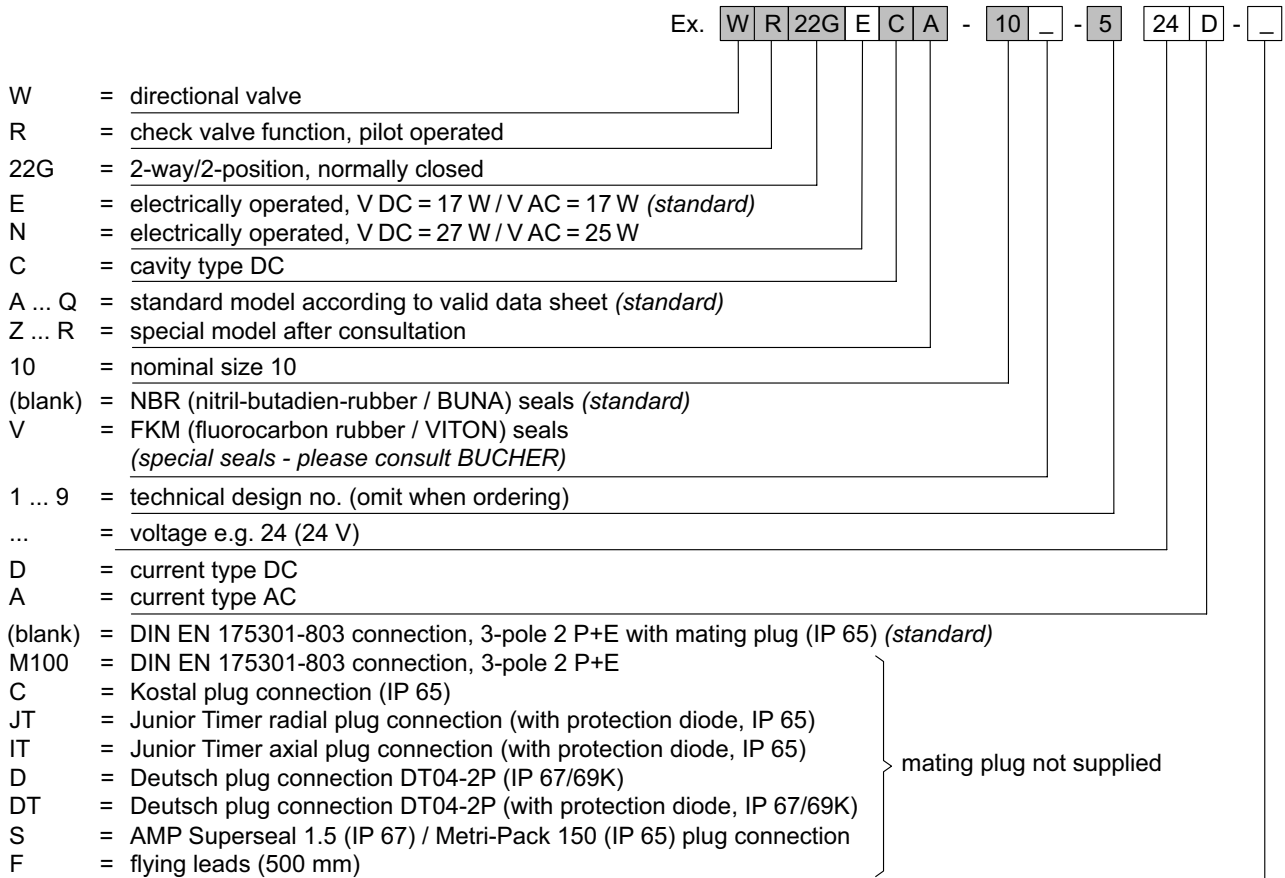

## Related data sheets

Reference	Description
400-P-040011	Forming tools
400-P-060111	Cavity DC
400-P-740101	Threaded port body DC-12
400-P-120110	Solenoid coil D36