

# D.0030600002

## Operating instructions (Translation)

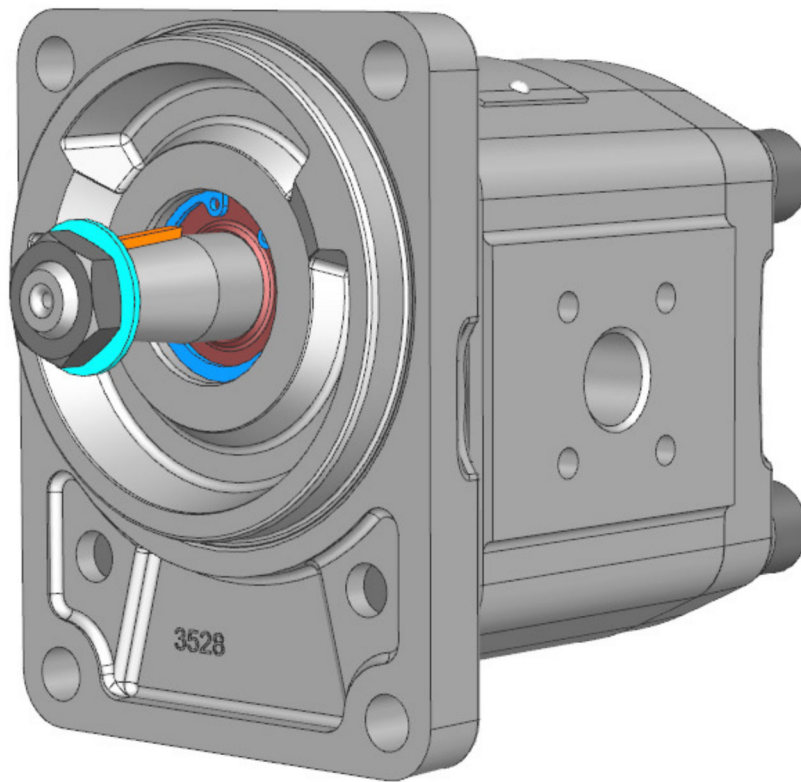

High pressure gear motor KM 1/. ... .4N.

88030600002-02

Englisch

2017-12-13

**KRACHT**

# Table of Content

<b>1</b>	<b>General</b>	<b>5</b>
1.1	About the documentation	5
1.2	Manufacturer's address	5
1.3	Applicable documents	5
1.4	Symbolism	6
<b>2</b>	<b>Safety</b>	<b>7</b>
2.1	Intended use	7
2.2	Personnel qualification and training	7
2.3	Basic safety instructions	7
2.4	Basic hazards	8
<b>3</b>	<b>Device description</b>	<b>10</b>
3.1	Functional principle	10
3.2	Basic design	11
3.3	Rotary and flow direction	12
3.4	Types of seals	13
3.5	Type key	14
3.6	Important special numbers	16
<b>4</b>	<b>Technical data</b>	<b>17</b>
4.1	General	17
4.2	Overview nominal sizes	18
4.3	Permissible pressure range	19
4.3.1	Working pressure feed side and drain side	19
4.3.2	Allocation speed - pressure on rotary shaft seal	20
4.4	Permissible temperature range	20
4.5	Material data	21
4.6	Weights	22
4.6.1	KM 1/.	22
4.6.2	KMA 1/.	23
4.7	Permissible radial forces	24
4.7.1	Version with outboard bearing L, tapered shaft	24
4.7.2	Version with outboard bearing P, tapered shaft	25

4.8	Dimensions	26
<b>5</b>	<b>Transport and storage</b>	<b>27</b>
5.1	General	27
5.2	Transport	27
5.3	Storage	27
<b>6</b>	<b>Installation</b>	<b>29</b>
6.1	Safety instructions for installation	29
6.2	Noise reduction	30
6.3	Mechanical installation	30
6.3.1	Preparation	30
6.3.2	Motors with free shaft end	31
6.3.3	Coupling Type "R."	32
6.3.4	KRACHT-Coupling "Shaft end F; X"	36
6.4	Connection lines	37
6.4.1	General	37
6.4.2	Feed line	37
6.4.3	Drain line and leakage oil line	37
6.4.4	Mounting Connection lines	38
6.5	Change of the direction of rotation	38
<b>7</b>	<b>Operation start-up</b>	<b>39</b>
7.1	Safety instructions for start-up	39
7.2	Preparation	39
7.3	Further operation start-up	39
<b>8</b>	<b>Removal</b>	<b>41</b>
8.1	Safety instructions for removal	41
8.2	Removal	42
<b>9</b>	<b>Maintenance</b>	<b>43</b>
9.1	Safety instructions for maintenance	43
9.2	Maintenance work	44
9.3	Maintenance instructions	44
<b>10</b>	<b>Repairs</b>	<b>46</b>
10.1	Safety instructions for repair	46

10.2	General	47
10.3	Detecting and eliminating failures	48

## 1 General

### 1.1 About the documentation

These operating instructions describe the installation, operation and maintenance of the following device:

#### **High pressure gear motor KM 1/. ... 4N..**

The device is manufactured in different versions. Information about the version concerned in the individual case can be found on the device's type plate.

These operating instructions are a component of the device and must be kept accessible for the personnel near the device at all times.

If required, the original documents can be requested from the respective manufacturer.

### 1.2 Manufacturer's address

KRACHT GmbH  
Gewerbestraße 20  
DE 58791 Werdohl  
phone: +49 2392 935-0  
fax: +49 2392 935-209  
email: [info@kracht.eu](mailto:info@kracht.eu)  
web: [www.kracht.eu](http://www.kracht.eu)

### 1.3 Applicable documents

1. KTR Kupplungstechnik GmbH, DE 48407 Rheine
  - KTR-N 40210: Coupling operating/assembly instruction Rotex

Excerpts from these documents are included in these operating instructions.

If required, the original documents can be requested from the respective manufacturer.

## 1.4 Symbolism



Identification of an immediate hazard, which would result in death or severe bodily injury if not avoided.



Identification of a potential medium risk hazard, which would lead to death or severe bodily injury if not avoided.



Identification of a low risk hazard, which could lead to minor or medium bodily injury if not avoided.



Flagging of notices to prevent property damage.



Identification of basic safety instructions. Non-compliance can lead to hazards for people and the device.



Flagging of special user tips and other especially useful or important information.

## 2 Safety

### 2.1 Intended use

1. The device has been designed for operation with fluid. Dry operation is not permitted.
2. The device may be operated in filled condition only.  
The medium must be compatible with the materials used in the device. The chemical competence is necessary for this. Be careful with ethylene oxide or other cathalytic or exothermic or self-decomposing materials. Please consult the manufacturer in cases of doubt.
3. The device may be operated only in usual industrial atmospheres. If there are any aggressive substances in the air, always ask the manufacturer.
4. Operation of the device is only permissible when complying with the operating instructions and applicable documents.  
Deviating operating conditions require the express approval of the manufacturer.
5. In case of any use of the device not according to specification, any warranty is voided.

### 2.2 Personnel qualification and training

The staff designated to assemble, operate and service the device must be properly qualified. This can be through training or specific instruction. Personnel must be familiar with the contents of this operating instructions.



Read the operating instructions thoroughly before use.

### 2.3 Basic safety instructions



1. Comply with existing regulations on accident prevention and safety at work along with any possible internal operator regulations.
2. Pay attention to the greatest possible cleanliness.
3. Wear suitable personal protection equipment.
4. Do not remove, make illegible or obliterate type plates or other references on the device.
5. Do not make any technical changes on the device.
6. Maintain and clean the device regularly.
7. Use spare parts approved by the manufacturer only.

## 2.4 Basic hazards

### DANGER

#### **Hazardous fluids!**

Danger of death when handling hazardous fluids.

1. Comply with the safety data sheets and regulations on handling hazardous fluids.
2. Collect and dispose of hazardous fluids so that no hazards arise for people or the environment.

### DANGER

#### **Rotating parts!**

Danger of death due to body parts, hair or clothing getting trapped or entangled.

1. Before all work, ensure that existing drives are voltage-free and pressure-free.
2. Securely prevent restarting during all work.

### DANGER

#### **Rotating parts!**

Danger of death due to body parts, hair or clothing getting trapped or entangled.

1. Take measures against accidental touching of rotating parts.

### WARNING

#### **Rotating parts!**

Danger of injury from flying parts.

1. Enclose rotating parts so as to avoid any danger from flying parts in the event of breakage or malfunction.

### WARNING

#### **Failure of load-carrying parts due to overload!**

Danger of injury from flying parts.

Danger of injury from spurting fluids.

1. Depressurise the device and all connection lines before doing any work.
2. Securely prevent the restoration of pressure while working on the device.





**WARNING**

**Failure of load-carrying parts due to overload!**

Danger of injury from flying parts.

Danger of injury from spurting fluids.

1. Use only connections and lines approved for the expected pressure range.
2. Securely prevent exceeding the permissible pressure, e.g. by using pressure relief valves or rupture discs.
3. Design pipework so that no tensions, e.g. caused by changes in length due to fluctuations in temperature, are transmitted to the device.



**WARNING**

**Failure of load-carrying parts due to overload!**

Danger of injury from flying parts.

Danger of injury from spurting fluids.

1. Do not operate the device against closed shut-off devices.
2. Do not operate the device in the false direction of rotation.

## 3 Device description

### 3.1 Functional principle

KM series pumps are external gear motors types that work according to the positive displacement principle.

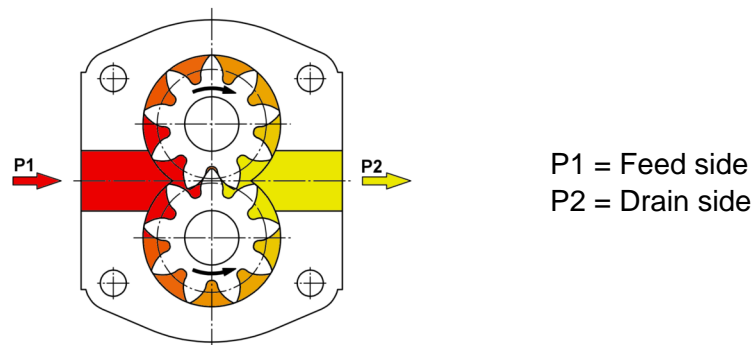

High pressure gear motors are used to convert hydraulic energy into mechanical energy. The hydraulic energy is generally generated by an upstream pump. With the aid of a suitable hydraulic fluid, the energy is output through two externally-toothed gears as the torque through the driven shaft to the consumer.

The configuration of a gear motor is fundamentally similar to a gear pump. They are manufactured for one or two directions of rotation. The geometric displacement volume  $V_g$  is consumed. A value that is stated in technical documents as the motor size.

According to its configuration, the KM external gear motors are classified as so-called gland-type bearing pumps. All the essential functional elements, gearing and gland bearings are located in an aluminium housing made of high-strength extrusion alloy closed on each side by the end cover or flanged cover. The gearing made of case-hardened steel with surface hardening consists of the driven shaft pinion and the driven shaft pinion. The gland bearings located on both sides of the gearing support the shaft journals and sealing elements in multi-component plain bearings which are used for pressure field sealing to compensate axial clearance.

The working pressure of the unit is reached only under load through the connected consumer. The speed of the unit here depends on the supplied pressure medium volume per time-unit.

Depending on the design and the application, the leakage oil is removed internally or externally.

### 3.2 Basic design

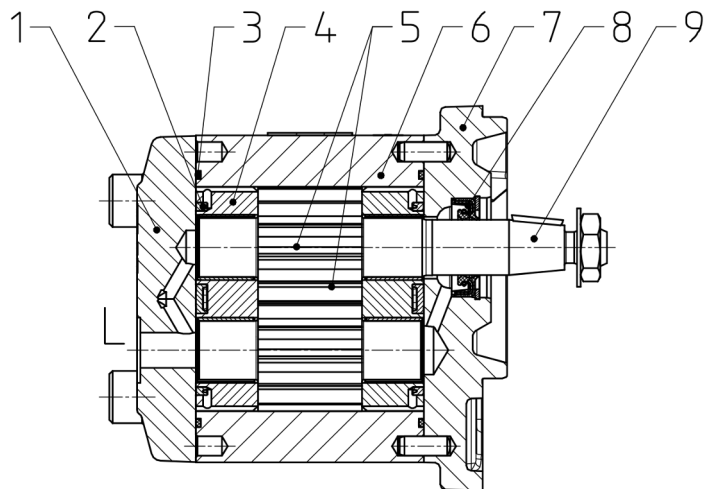

#### Explanation

- |   |  |
|---|--|
| 1. End cover  | 6. Housing                                       |
| 2. Pressure field seal for axial clearance compensation | 7. Flange cover                                  |
| 3. Housing seal   | 8. Shaft seal<br>(see "Section: Seal types")     |
| 4. Gland bearing with multilayer friction bearings      | 9. Output shaft end<br>(see "Section: Type key") |
| 5. Gears  | L Leak oil connection<br>(depending on version)  |

### 3.3 Rotary and flow direction

With regard to the rotary and flow direction of external gear pumps, when looking at the driven shaft end the following definition applies:

Looking at the driven shaft end, the flow direction is from left to right when the shaft is moving clockwise.

Looking at the driven shaft end, the flow direction is from right to left when the shaft is moving counter-clockwise.

#### High pressure gear motor with end cover

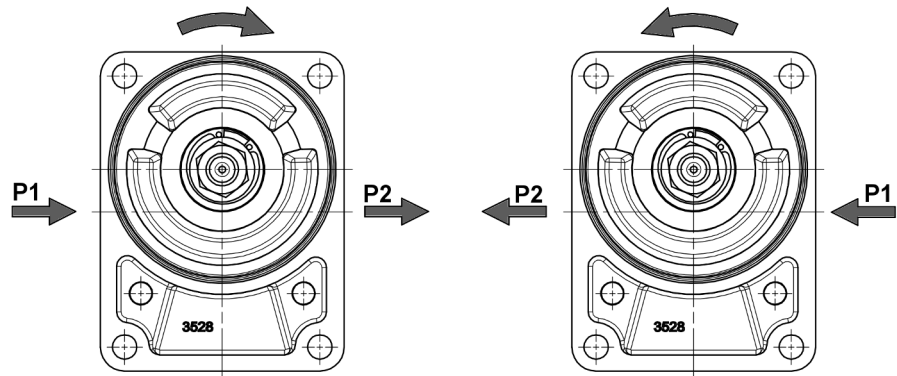

P1 = Feed side  
P2 = Drain side

The direction of rotation is indicated by the bent arrow.

The flow direction is indicated by the straight arrow.

### 3.4 Types of seals

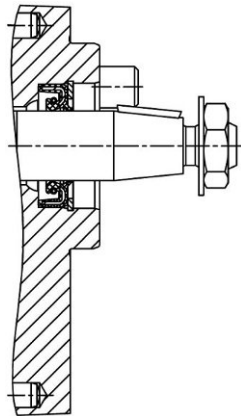

Rotary shaft seal  
*Seal type: 1; 2*

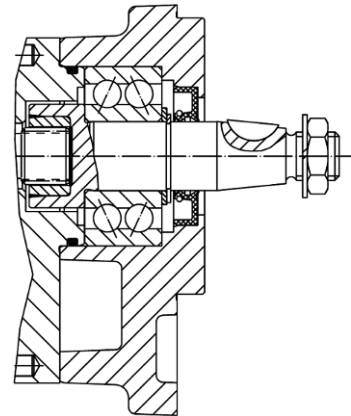

Rotary shaft seal with outboard bearing, Light-duty design  
*Seal type: 1; 2*

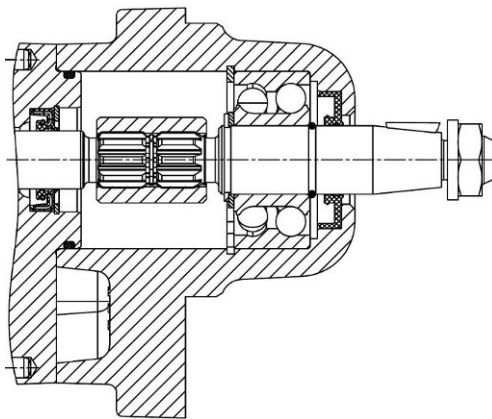

Rotary shaft seal with outboard bearing, heavy-duty version  
*Seal type: 1; 2*

## 3.5 Type key

Ordering example																
KM	A	1/	5.5	G	3	0	A	K	0	A	4	N	L	1	/...	...
1.	2.	3.	4.	5.	6.	7.	8.	9.	10.	11.	12.	13.	14.	15.	16.	17.

Explanation of type key			
<b>1.</b>	<b>Product name</b>		
<b>2.</b>	<b>Material design</b>		
<b>A</b>	Housing: AlMgSi1Cu End cover/Flange cover: EN AW-6082	<b>Without</b>	Housing: AlMgSi1Cu End cover/Flange cover: EN-GJS-400-15
<b>3.</b>	<b>Size</b>		
<b>4.</b>	<b>Nominal size</b>		
<b>V<sub>gn</sub></b>	5.5; 6.3; 8; 9.6; 11; 14; 16; 19; 22; 25		
<b>5.</b>	<b>Flange cover version</b>		
<b>A</b>	SAE-A-2-hole flange LA = 106.4; ØZ = 82.55	<b>L</b>	Square 2-hole flange LA = 60/60; ØZ = 52 with O-ring (without shaft seal)
<b>F</b>	Square 2-hole flange LA = 60/60; ØZ = 50	<b>M</b>	as version F; but with attachment bore holes mirrorinverted
<b>G</b>	Rectangular 4-hole flange LA = 72/100; ØZ = 80	<b>Q</b>	Square 2-hole flange LA = 60/60; ØZ = 52 with O-ring
<b>K</b>	Rectangular 4-hole flange LA = 71.4/96.1; ØZ = 36.47		
	<b>LA</b> = Hole distance <b>Ø</b> = Centering diameter		
<b>6.</b>	<b>Direction of rotation</b>		
<b>1</b>	Clockwise	<b>3</b>	Clockwise and counterclockwise
<b>2</b>	Counterclockwise		
<b>7.</b>	<b>Outboard flange / Outbord bearing</b>		
<b>0</b>	Without	<b>P</b>	Outbord bearing, heavy-duty version
<b>L</b>	Outbord bearing, Light-duty design	<b>R</b>	Attachment angle
<b>8.</b>	<b>Housing connection</b>		
<b>A</b>	Ø15/LK35	<b>J</b>	7/8 - 14 UNF
<b>C</b>	G1/2	<b>Q</b>	Ø13.5/LK30.2
<b>D</b>	M22x1.5		

Explanation of type key			
<b>9. Shaft end</b> <sup>(1)</sup>			
<b>F</b>	Flat plug (M <sub>max.</sub> = 40 Nm)	<b>S</b>	Gear shaft profile SAE-A DP 16/32; α = 30°; z = 9 (M <sub>max.</sub> = 55 Nm)
<b>K</b>	Cone 1:5 (M <sub>max.</sub> = 160 Nm)	<b>X</b>	Gear shaft profile B 17x14 DIN 5482 (M <sub>max.</sub> = 70 Nm)
<b>M</b>	Cone 1:8 (M <sub>max.</sub> = 160 Nm)		
<b>10. 2nd shaft end</b>			
<b>0</b>	Without	<b>X</b>	Gear shaft profile B 17x14 DIN 5482
<b>11. End cover (Adapter)</b>			
<b>0A</b>	End cover (Standard version)	<b>0F</b>	End cover (Leakage oil connection rear 7/16-20 UNF)
<b>0B</b>	End cover (Leakage oil connection lateral)	<b>XF</b>	Adapter (multi-stage version KM 1/. + KM 1/.)
<b>12. Design serial number</b> (specified by manufacturer)			
<b>13. Code for materials</b>			
<b>N</b>	Housing material AlMgSi1Cu Gland bearing with multilayer friction bearings		
<b>14. Gears version</b>			
<b>L</b>	Driving shaft pinion and driven shaft pinion are made of cast-hardened steel, milled tooth flanks	<b>M</b>	Driving shaft pinion and driven shaft pinion are made of cast-hardened steel, Reduced tooth clearance
<b>15. Seal</b>			
<b>1</b>	Rotary shaft seal NBR (VU)	<b>2</b>	Rotary shaft seal FKM (VU)
<b>16. Code for special versions</b>			
<b>17. Version</b>			
<b>Without</b>	one-stage version (Standard)		
<b>+</b>	multi-stage version		
<sup>(1)</sup> F; S; X: Lubrication required			

### 3.6 Important special numbers

Special number	Description
324	Shaft end, outboard bearing: Ø17 mm, Cone 1:5 (Shaft end F: $M_{max.} = 40 \text{ Nm}$ ) (Shaft end X: $M_{max.} = 70 \text{ Nm}$ )
375	Shaft end, outboard bearing: Ø17 mm/Ø20 mm, Cone 1:5 (See rating plate/accompanying documents) Flange pattern outboard bearing and flanged cover version F (Shaft end F: $M_{max.} = 40 \text{ Nm}$ ) (Shaft end X: $M_{max.} = 70 \text{ Nm}$ )



## 4 Technical data

### 4.1 General

General information		
<b>Design</b>	External gear motor	
<b>Fixing type</b>	Flange; Foot mounting	
<b>Shaft end</b>	See <a href="#">section 3.5 "Type key"</a>	
<b>Housing connection</b>	See <a href="#">section 3.5 "Type key"</a>	
<b>Mounting position</b>	Any <sup>(1)</sup>	
<b>External loads on shaft end</b>	See <a href="#">section 4.2 "Overview nominal sizes"</a>	
<b>Speed</b>	<b>n</b>	See <a href="#">section 4.2 "Overview nominal sizes"</a>
<b>Operating pressure Feed side</b>	<b>p<sub>1</sub></b>	See <a href="#">section 4.3.1 "Working pressure feed side and drain side"</a>
<b>Operating pressure Drain side</b>	<b>p<sub>2</sub></b>	
<b>Leakage oil backpressure external</b>	<b>p<sub>T</sub></b>	See <a href="#">section 4.3.2 "Allocation speed - pressure on rotary shaft seal"</a>
<b>Viscosity</b>	<b>v<sub>min</sub></b>	10 mm <sup>2</sup> /s
	<b>v<sub>max</sub></b>	600 mm <sup>2</sup> /s
<b>Recommendet viscosity range</b>	<b>v<sub>min</sub></b>	30 mm <sup>2</sup> /s
	<b>v<sub>max</sub></b>	45 mm <sup>2</sup> /s
<b>Fluid temperature range</b>	<b>ϑ<sub>m</sub></b>	See <a href="#">section 4.4 "Permissible temperature range"</a>
<b>Ambient temperature</b>	<b>ϑ<sub>u</sub></b>	
<b>Filter porosity</b>	<b>β</b>	β <sub>25</sub> ≥ 75 for ...300 bar β <sub>40</sub> ≥ 75 for ...100 bar
<b>Material</b>	See <a href="#">section 4.5 "Material data"</a>	
<b>Oil cleanliness</b>	NAS 1638 Class 10 Compliant with ISO 4406: 1999 Class 21/19/16	
<b>Permissible media</b>	Mineral oil according to DIN 51524/25 Motor oil according to DIN 51511 Bio-oils of the "HEES" group can be used up to 70 °C and at maximum pressure reduced by about 20 %	
<sup>(1)</sup> A reduced service life must be expected for the shaft seal in the case of vertical installation (shaft end top).		

## 4.2 Overview nominal sizes

Nominal size $V_{gn}$	Geom. displacement $V_g$ [cm <sup>3</sup> /rev.]		Speed n		Perm. radial force <sup>(1)</sup> $F_{radial}$ [N]	Permissible axial force $F_{axial}$ [N]	Mass inertia $\times 10^{-6}$ J [kg m <sup>2</sup> ]
	KM 1/. .. 4NL.	KM 1/. .. 4NM.	$n_{min}$ [rpm]	$n_{max}$ [rpm]			
5.5	5.45	5.6	200	4000	See section 4.7 "Permissible radial forces"	-	35.7
6.3	6.28	6.45					39.9
8	7.9	8.16					51.1
9.6	9.59	9.86					56.5
11	10.9	11.2					62.9
14	13.85	14.25					77.7
16	15.9	16.32					87.7
19	18.8	19.37					102.5
22	22.3	22.9					119.6
25	25.21	25.97					135.3

<sup>(1)</sup> Outside forces are only permissible in combination with an outboard bearing.  $F_{radial}$  on central shaft end.

### 4.3 Permissible pressure range

#### 4.3.1 Working pressure feed side and drain side

Nominal size $V_{gn}$	Operating pressure <sup>(1)</sup>				
	Drain side		Feed side		
	external leak oil discharge $p_{2\ max}$ [bar]	Internal leakage oil removal $p_{2\ max}$ [bar]	$p_{\max}$ [bar] (Maximum pressure)	$p_N$ [bar] (Nominal pressure)	$p_D$ [bar] (Permanent pressure)
5.5	120	See section 4.3.2 "Allocation speed - pressure on rotary shaft seal"	300	280	250
6.3					
8					
9.6					
11			260	240	210
14					
16					
19			220	200	180
22					
25			200	180	150

<sup>(1)</sup> Comply with permissible speed for shaft end.

## 4.3.2 Allocation speed - pressure on rotary shaft seal

### Permissible pressure range

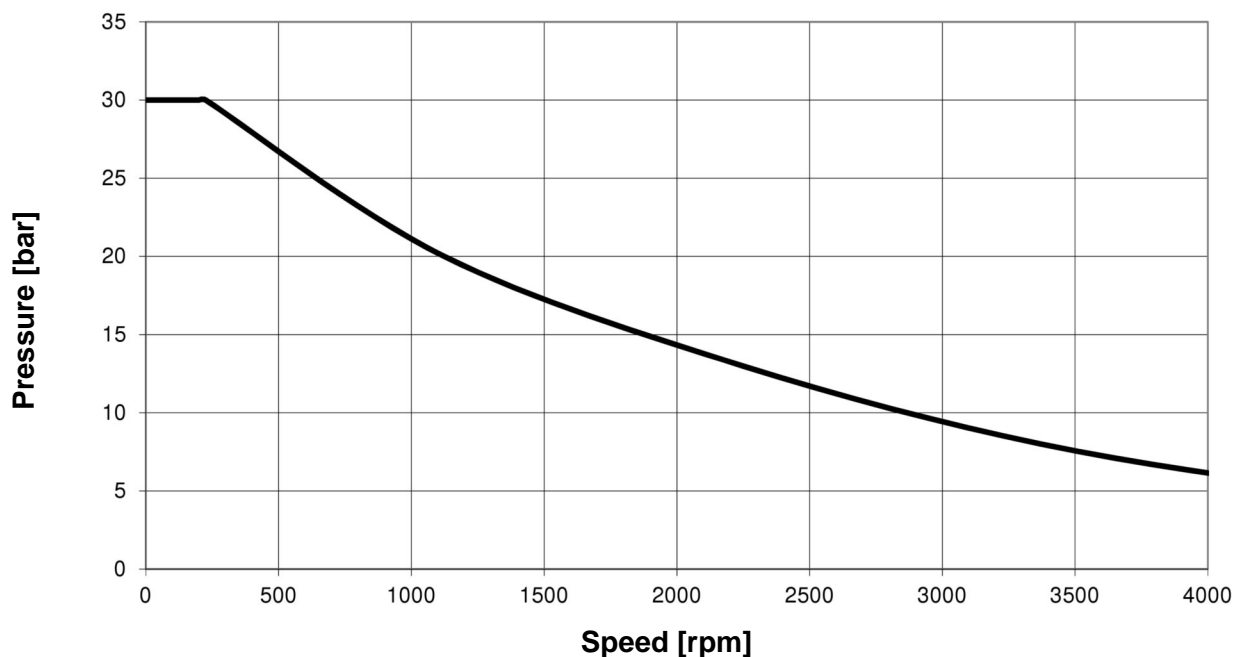

## 4.4 Permissible temperature range

Sealing material	Fluid temperature range $\vartheta_m$	
	$\vartheta_{m \min}$ [°C]	$\vartheta_{m \max}$ [°C]
NBR/P5000	-20	90
FKM/P5000	-15	100

Sealing material	Ambient temperature $\vartheta_u$	
	$\vartheta_{u \min}$ [°C]	$\vartheta_{u \max}$ [°C]
NBR/P5000	-20	60
FKM/P5000	-15	

#### 4.5 Material data

Seal type <sup>(1)</sup>		Material						
		Shaft seal	O-Ring	Housing	End cover/ Flange cover	Gears	Bearing	Seal compression spring
1	WDR (VU)	NBR	NBR	AlMg-Si1Cu	EN AW-6082 - - -	Case-hardened steel (1.7139)	Plain bearings Al - - -	P5000 (TPU)
2	WDR (VU)	FKM	FKM		EN-GJS-400-15 (GGG-40)		Multi layer friction bearings	
<sup>(1)</sup> WDR: Rotary shaft seal								

## 4.6 Weights

### 4.6.1 KM 1/.

Nominal size $V_{gn}$	Weight Motor [kg]					
	Flange cover					
	A	F / Q / M	G	K	L	F with mounting bracket
5.5	3.2	2.8	3.2	2.6	2.7	4.3
6.3	3.3	2.9	3.3	2.7	2.8	4.5
8						
9.6	3.4	3.0	3.4	2.8	2.9	4.6
11	3.5	3.1	3.5	2.9	3.0	4.7
14	3.6	3.2	3.6	3.0	3.1	4.8
16	3.8	3.4	3.8	3.2	3.2	5.0
19	3.9	3.5	3.9	3.3	3.4	5.1
22	4.1	3.7	4.1	3.5	3.6	5.3
25	4.3	3.9	4.3	3.7	3.8	5.5

Nominal size $V_{gn}$	Weight Motor with outboard bearing [kg]				
	Version with outboard bearing L, tapered shaft			Version with outboard bearing P, tapered shaft	
	Flange cover			Flange cover	
	A	F	G	L	Q
5.5	4.6	3.6	3.7	6.2	6.3
6.3	4.7	3.7	3.8	6.3	6.4
8					
9.6	4.8	3.8	3.9	6.4	6.5
11	4.9	3.9	4.0	6.5	6.6
14	5.0	4.0	4.1	6.6	6.7
16	5.1	4.1	4.2	6.7	6.9
19	5.3	4.3	4.4	6.9	7.0
22	5.5	4.5	4.6	7.1	7.2
25	5.7	4.7	4.8	7.3	7.4

## 4.6.2 KMA 1/.

Nominal size $V_{gn}$	Weight Motor [kg]					
	Flange cover					
	A	F / Q / M	G	K	L	F with mounting bracket
5.5	2.1	1.8	2.2	1.9	1.8	3.3
6.3	2.2	1.9	2.3	2.0	1.9	3.5
8						
9.6	2.3	2.0	2.4	2.1	2.0	3.6
11	2.4	2.1	2.5	2.2	2.1	3.7
14	2.5	2.2	2.6	2.3	2.2	3.8
16	2.7	2.4	2.8	2.5	2.3	4.0
19	2.8	2.5	2.9	2.6	2.5	4.1
22	3.0	2.7	3.1	2.8	2.7	4.3
25	3.2	2.9	3.3	3.0	2.9	4.5

Nominal size $V_{gn}$	Weight Motor with outboard bearing [kg]			
	Version with outboard bearing L, tapered shaft			Version with outboard bearing P, tapered shaft
	Flange cover			Flange cover
	A	F	G	L / Q
5.5	3.5	2.6	2.7	5.3
6.3	3.6	2.7	2.8	5.4
8				
9.6	3.7	2.8	2.9	5.5
11	3.8	2.9	3.0	5.5
14	3.9	3.0	3.1	5.7
16	4.0	3.1	3.2	5.8
19	4.2	3.3	3.4	6.0
22	4.4	3.5	3.6	6.2
25	4.6	3.7	3.8	6.4

## 4.7 Permissible radial forces

### 4.7.1 Version with outboard bearing L, tapered shaft



Ordering example: **KM 1/8 L3LA F0A 4NL1**

Permissible radial forces  $F_{R \max}$  as a function of the bracing force  $l$  at a given axial force  $F_A$  ( $L_h = 10.000$  h), centre of shaft at  $l = 21.5$  mm

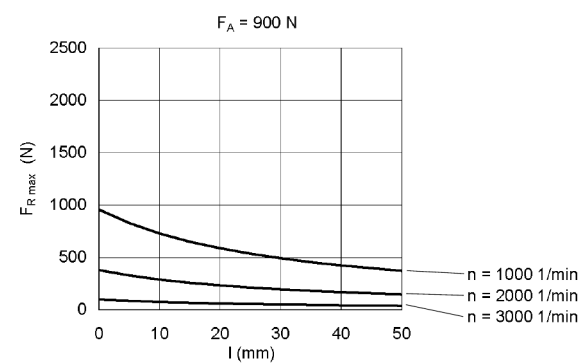
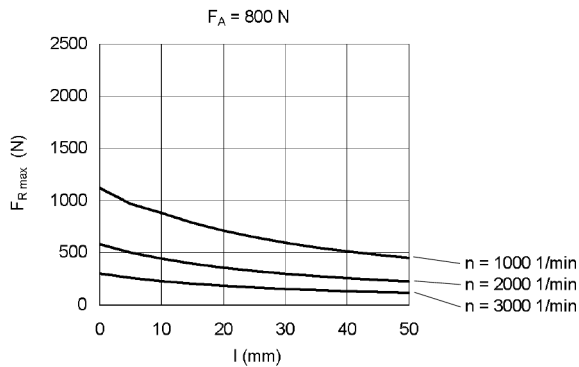
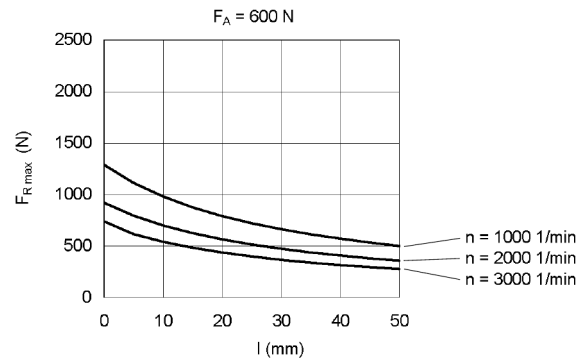
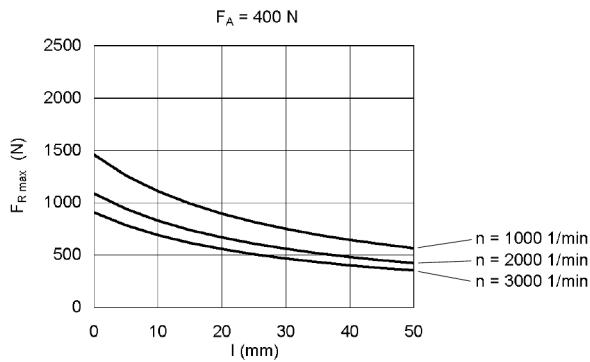
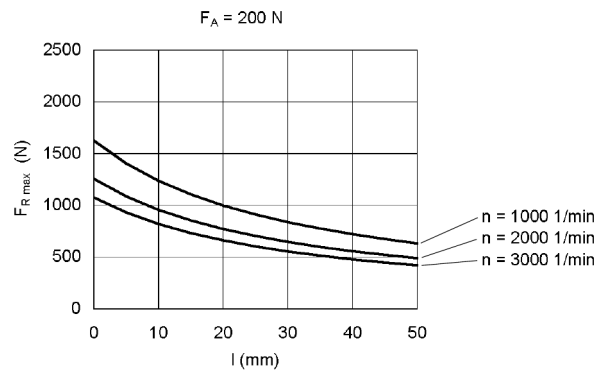
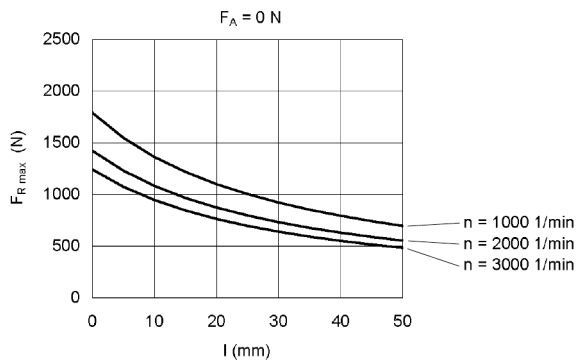



**4.7.2 Version with outboard bearing P, tapered shaft**

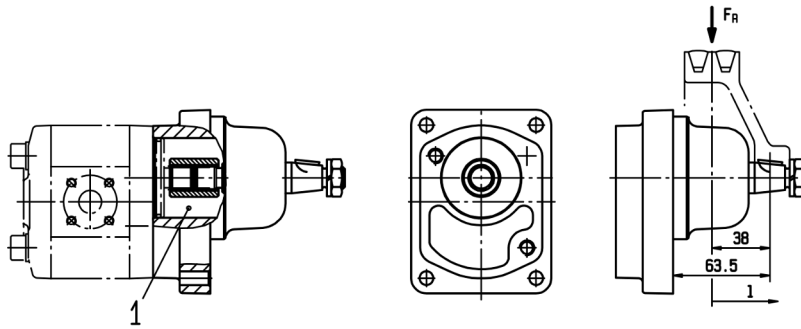

1. Before assembly, fill with 50 cm<sup>3</sup> oil (ISO VG 10-68).

Ordering example: **KM 1/8 Q3PA X0A 4NL1**

Permissible radial forces  $F_{R\ max}$  as a function of the bracing force  $l$  at a given axial force  $F_A$  ( $L_h = 10.000\ h$ ), centre of shaft at  $l = 38\ mm$

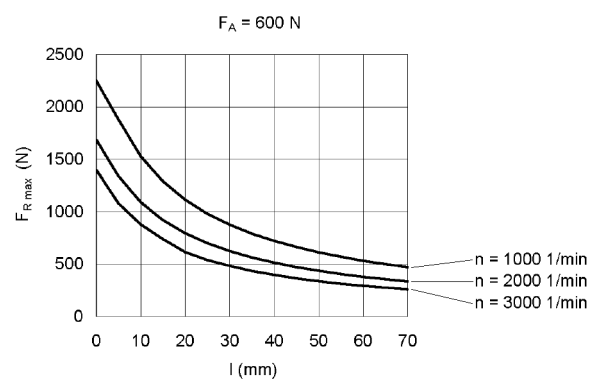
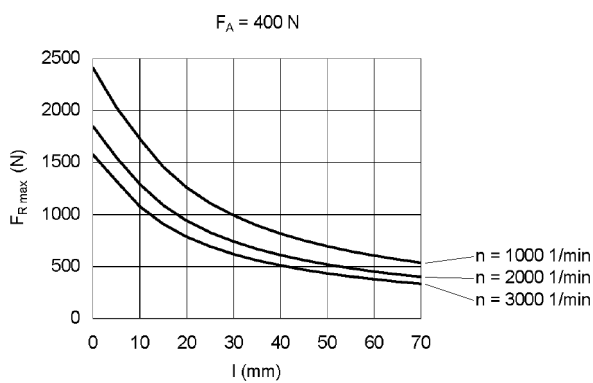
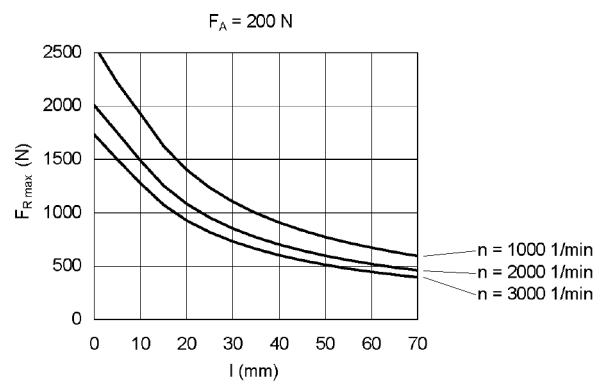
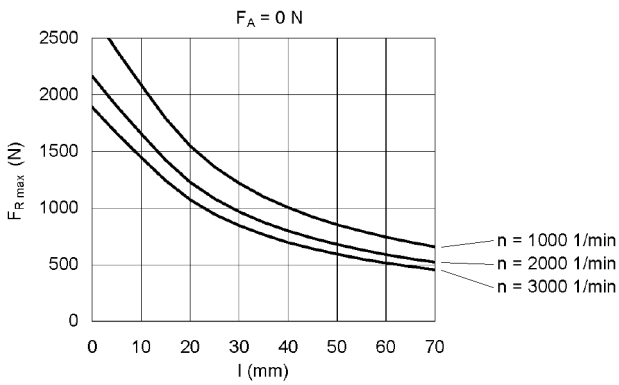

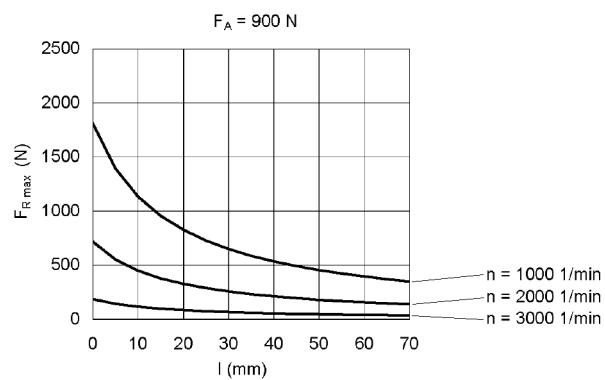
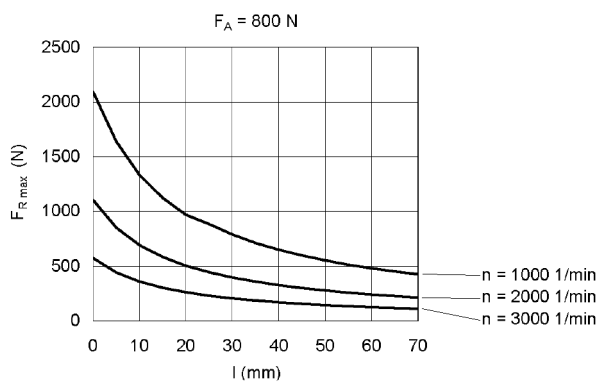

### 4.8 Dimensions

Dimensions of the device can be found in the relevant technical data sheets.

## 5 Transport and storage

### 5.1 General

- After receipt, check the device for transport damages.
- If transport damage is noticed, report this immediately to the manufacturer and the carrier. The device must then be replaced or repaired.
- Dispose of packing material and used parts in accordance with the local stipulations.

### 5.2 Transport



#### **Falling or overturning loads!**

Danger of injury while transporting large and heavy loads.

1. Use only suitable means of conveyance and lifting tackle with sufficient load-bearing capacity.
2. Attach lifting tackle only to suitable load points.
3. Attach the lifting tackle in such a manner that it cannot slip.
4. Pay attention to the load balance point.
5. Always avoid jerks, impacts and strong vibrations during transportation.
6. Never walk under suspended loads, never work under suspended loads.

### 5.3 Storage

The device's function is tested in the plant with mineral hydraulic oil. Then all connections are closed. The remaining residual oil preserves the interior parts for up to 6 months.

Metallic exposed exterior parts are protected against corrosion by suitable conservation measures, also up to 6 months.

In case of storage, a dry, dust-free and low-vibration environment is to be ensured. The device is to be protected against influences from weather, moisture and strong fluctuations of temperature. The recommended storage conditions are to be adhered to.

Below the permissible ambient temperature  $\vartheta_u$  elastomer seals lose their elasticity and mechanical loading capacity, since the glass transition temperature is fallen below. This procedure is reversible. A force action on the device is to be avoided in case of storage below the permissible ambient temperature  $\vartheta_u$ .

Devices with EPDM seals are not mineral-oil resistant and are not tested for their function. There is no preservation of the interior parts. If the device is not taken into operation immediately, all corrosion-prone surfaces are to be protected by suitable conservation measures. The same applies for devices which are not tested for other reasons.

When storing for a long period of time (> 6 months), treat all surfaces at risk of corrosion again with suitable preserving agents.

If high air humidity or aggressive atmospheres are expected, take additional corrosion-preventing measures.



Storage in corrosion protection bags (VCI) maximum of 6 months.



## NOTICE

### Corrosion/chemical impact

Improper storage can render the device useless.

1. Protect endangered surfaces by means of suitable conservation measures.
2. Comply with recommended storage conditions.



### Recommended storage conditions

1. Storage temperature: 5 °C - 25 °C
2. Relative air humidity: < 70 %
3. Protect elastomer parts from light, especially direct sunlight.
4. Protect elastomer parts from oxygen and ozone.
5. Comply with maximum storage times of elastomeric parts:
  - 5 Years: AU (Polyurethane rubber)
  - 7 Years: NBR, HNBR, CR
  - 10 Years: EPM, EPDM, FEP/PTFE, FEPM, FKM, FFKM, VMQ, FVMQ

## 6 Installation

### 6.1 Safety instructions for installation

#### DANGER

##### **Hazardous fluids!**

Danger of death when handling hazardous fluids.

1. Comply with the safety data sheets and regulations on handling hazardous fluids.
2. Collect and dispose of hazardous fluids so that no hazards arise for people or the environment.

#### DANGER

##### **Rotating parts!**

Danger of death due to body parts, hair or clothing getting trapped or entangled.

1. Before all work, ensure that existing drives are voltage-free and pressure-free.
2. Securely prevent restarting during all work.

#### DANGER

##### **Rotating parts!**

Danger of death due to body parts, hair or clothing getting trapped or entangled.

1. Take measures against accidental touching of rotating parts.

#### WARNING

##### **Rotating parts!**

Danger of injury from flying parts.

1. Enclose rotating parts so as to avoid any danger from flying parts in the event of breakage or malfunction.

#### WARNING

##### **Unshielded gearwheels!**

Gearwheels can trap and crush fingers and hands.

1. Do not engage gearwheels.



## WARNING

### Failure of load-carrying parts due to overload!

Danger of injury from flying parts.

Danger of injury from spurting fluids.

1. Depressurise the device and all connection lines before doing any work.
2. Securely prevent the restoration of pressure while working on the device.

## 6.2 Noise reduction



### Measures for noise reduction

1. Use suction and pressure hoses.
2. Use bell housings with high damping properties (plastic or cast iron).
3. Use of damping rings and damping rods for separation of structure-borne noise.

## 6.3 Mechanical installation

### 6.3.1 Preparation

- Check the device for transport damage and dirt.
- Check the device for freedom of movement.
- Remove existing preservatives.
  - Use only those cleaning agents that are compatible with the materials used in the device.
  - Do not use cleaning wool.
- Compare the environmental and ambient conditions at the place of installation to the permissible conditions.
  - Ensure a sufficiently stable and level foundation.
  - Expose the device only to small vibrations, see IEC 60034-14.
  - Secure sufficient access for maintenance and repair.

### 6.3.2 Motors with free shaft end

The prerequisite for trouble-free operation is suitable load transmission between the motor and the consumer. By default a torsionally flexible claw coupling Type "R" is used for this.

- Pre-mount coupling parts as per manufacturer's specifications.



Torsionally flexible claw coupling type "R.": See [section 6.3.3 "Coupling Type "R.""](#)



Coupling "Shaft end F; X": See [section 6.3.4 "KRACHT-Coupling "Shaft end F; X""](#)

- Place the motor and the consumer together.
  - Comply with the permissible mounting position.
  - Comply with the permissible direction of rotation.



Rotary and flow direction: See [chapter 3 "Device description"](#)

- Tighten all fastening screws with the specified torque.
  - Keep to the permissible displacement values of the coupling.
  - Rule out any distortion of the device.
  - Pay attention to sufficient screw-in depth of the fastening screws.

Tightening torques [Nm]		
<b>Fastening screws</b>	<b>M10</b>	50 <sup>+10</sup> Nm
<b>Hexagonal nut with the tapered shaft end design</b>	<b>M12x1.5</b>	30 Nm
	<b>M14x1.5</b>	63 Nm

- Make sure that the leakage oil is drawn-off controlled and does not get into the environment.
- Make sure no foreign bodies can get into the device.
- Take measures against accidental touching of rotating parts.
- Take measures against accidental touching of hot surfaces (> 60 °C).

### 6.3.3 Coupling Type "R."

Claw couplings Type "R." are torsionally flexible and transmit the torque positive. They are fail-safe. The vibrations and impacts that occur during operation are effectively dampened and reduced.

#### Claw coupling Type "R."

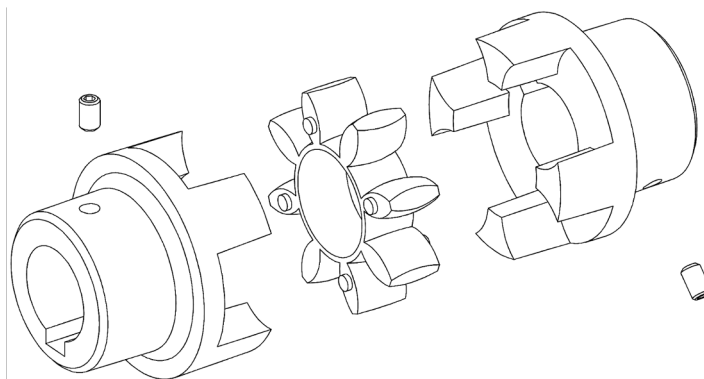

#### NOTICE

##### **Coupling breakage or increased wear**

An overload can lead to premature failure of the coupling.

1. Ensure safe dimensioning when designing the coupling. Take vibrations, torque peaks and temperatures into account.



**Assembly data**

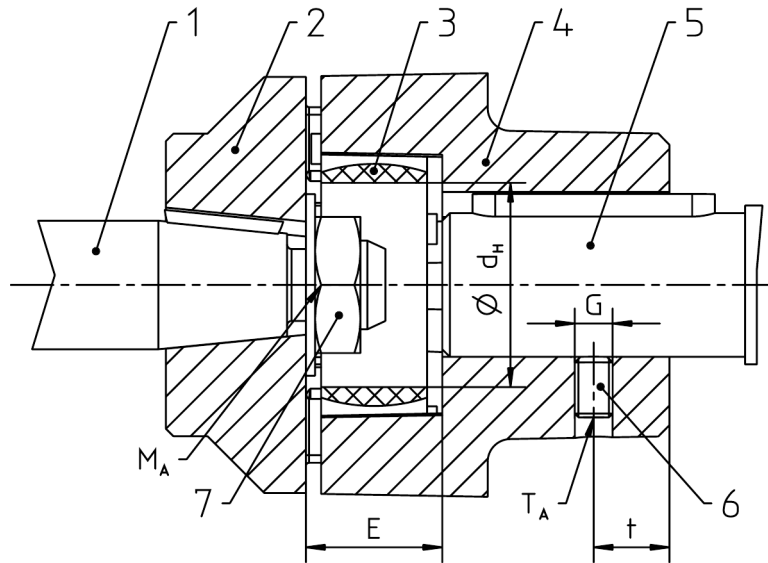

**Explanation**

- |                     |                        |
|---------------------|------------------------|
| 1. Output shaft end | 5. Shaft end, consumer |
| 2. Coupling half    | 6. Setscrew            |
| 3. Spider           | 7. Hexagonal nut       |
| 4. Coupling half    |                        |

When installing the coupling, maintain the "E" gap dimension so that the spider remains free during operation. If the shaft diameters are less than (also with parallel key) the dimension  $d_H$  of the spider, the shaft ends can protrude out into the spider.

Coupling size <sup>(1)</sup>	14	19	24	28	38	42	48	55	65	75
	-	19/24	24/28	28/38	38/45	42/55	48/60	55/70	65/75	75/90
Coupling clearance E [mm]	13	16	18	20	24	26	28	30	35	40
$d_H$ [mm]	10	18	27	30	38	46	51	60	68	80
G	M4	M5	M5	M8	M8	M8	M8	M10	M10	M10
t [mm]	5	10	10	15	15	20	20	20	20	25
<b>Tightening torque</b>										
T [Nm]	1.5	2	2	10	10	10	10	17	17	17
$M_A$ [Nm]	M12x1.5	30								
	M14x1.5	63								
<sup>(1)</sup> Example: R.19-K18/17-Z30/24 or R.19/24-K18/17-Z30/28.										



For assembly, the coupling halves can be heated to approx. 80 °C and pushed onto the shaft ends while warm.



**Hot surfaces!**

Burn injury to skin if touched.

1. Wear protective gloves at temperatures  $\geq 48^{\circ}\text{C}$ .

- Mount the coupling halves on the shaft ends but avoid impacts on the components.
- Position the coupling halves on the shaft ends so that in later operation the "E" gap dimension is maintained.
- Secure the coupling halves by tightening the setscrews.
- Insert the spider in a coupling half.

**Displacement values**

**Axial displacement**  
 $\Delta K_a$

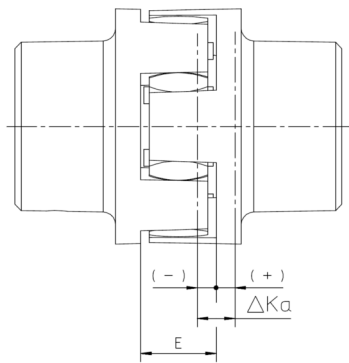

**Radial displacement**  
 $\Delta K_r$

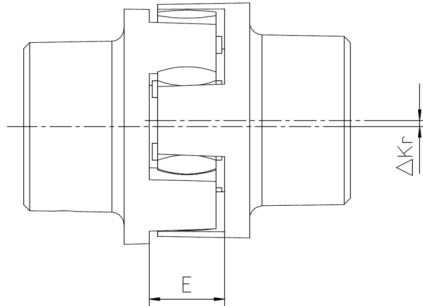

**Angular displacement**  
 $\Delta K_w / \Delta K_L$

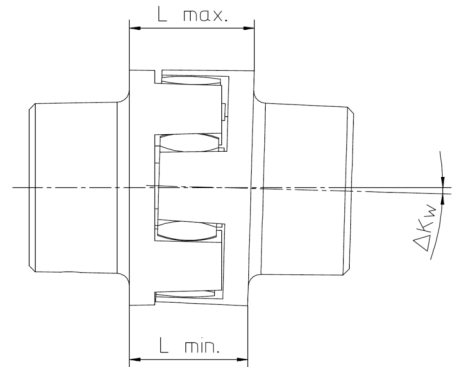

$$\Delta K_L \triangleq L_{max} - L_{min}$$

Coupling size		14	19	24	28	38	42	48	55	65	75
		-	19/24	24/28	28/38	38/45	42/55	48/60	55/70	65/75	75/90
Coupling clearance E [mm]		13	16	18	20	24	26	28	30	35	40
$\Delta K_a$ [mm]		+1.0 -0.5	+1.2 -0.5	+1.4 -0.5	+1.5 -0.7	+1.8 -0.7	+2.0 -1.0	+2.1 -1.0	+2.2 -1.0	+2.6 -1.0	+3.0 -1.5
$\Delta K_r$ [mm]	1500 rpm	0.11	0.13	0.15	0.18	0.21	0.23	0.25	0.27	0.30	0.34
	3000 rpm	0.08	0.09	0.1	0.13	0.15	0.16	0.18	0.19	0.21	0.24
$\Delta K_w$ [Degree]	1500 rpm	1.1	1.1	0.8	0.8	0.9	0.9	1.0	1.0	1.1	1.1
	3000 rpm	1.0	1.0	0.7	0.7	0.8	0.8	0.9	0.9	1.0	1.0
$\Delta K_L$ [mm]	1500 rpm	0.57	0.77	0.77	0.90	1.25	1.40	1.80	2.00	2.50	3.00
	3000 rpm	0.52	0.7	0.67	0.80	1.00	1.30	1.60	1.80	2.20	2.70

### Displacement combinations

Examples for displacement combinations shown in the photo opposite:

*Example 1:*

$$\Delta K_r = 30 \%$$

$$\Delta K_w = 70 \%$$

*Example 2:*

$$\Delta K_r = 60 \%$$

$$\Delta K_w = 40 \%$$

$$\Delta K_r + \Delta K_w \leq 100 \%$$

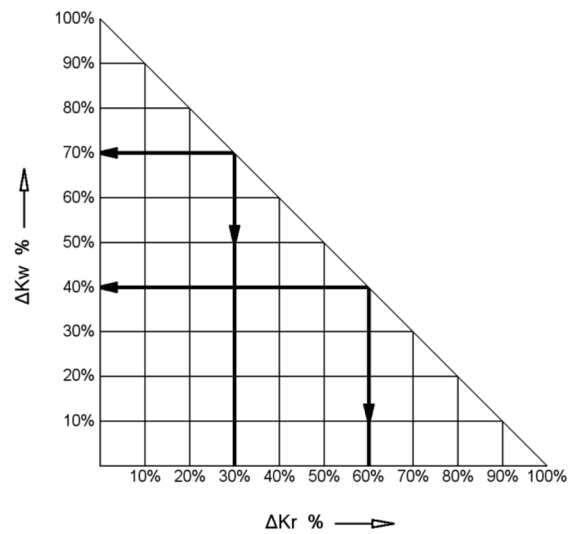

### 6.3.4 KRACHT-Coupling "Shaft end F; X"

**Coupling sleeve KP 1 GR.1**  
Shaft end X

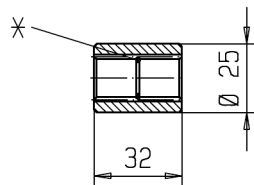

**Coupling KP 1L**  
Shaft end F

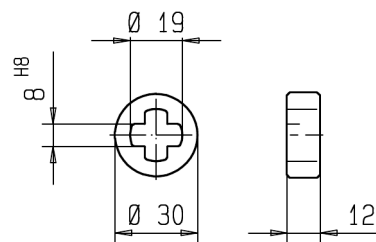

#### NOTICE

##### **Wear**

Dry running leads to premature wear of the shaft ends.

1. When driving through the shaft ends F, S and X and when using the Kracht couplings, sufficient lubrication must be ensured.

## 6.4 Connection lines

### 6.4.1 General



#### WARNING

##### Failure of load-carrying parts due to overload!

Danger of injury from flying parts.

Danger of injury from spurting fluids.

1. Use only connections and lines approved for the expected pressure range.
2. Securely prevent exceeding the permissible pressure, e.g. by using pressure relief valves or rupture discs.
3. Design pipework so that no tensions, e.g. caused by changes in length due to fluctuations in temperature, are transmitted to the device.



##### Additional connections

1. Provide measurement connections for pressure and temperature as close as possible to device.
2. If necessary, provide a facility to fill or empty the device and the line system.
3. If necessary, provide a facility to vent the device and the line system.

### 6.4.2 Feed line

A feed line that is not optimally planned can lead to increased noise emissions, cavitation and a reduction of the flow rate.

When designing the line, take the following points into consideration:

- The nominal width of the feed line must be selected so that the permissible operating pressure  $p_{max}$  is not exceeded on the feed side.
- Install a pressure relief valve with return to the reservoir as close as possible to the feed connection of the unit.
- Comply with the recommended flow velocity in the feed line (3 m/s - 5 m/s).

### 6.4.3 Drain line and leakage oil line

When designing the lines, comply with the following points:

- Install the lines as short as possible and in a straight line.
- The nominal width of the drain line must be selected such that the maximum permissible pressures are not exceeded.
- Avoid additional pressure loss through line resistances such as fittings, screwed connections, formed parts or suction filters/suction baskets.

Ensure that all technically required suction filters/suction baskets are appropriately dimensioned.

- Comply with the recommended flow velocity in the drain line (0.5 m/s - 1.5 m/s).



Install a pressure relief valve with return to the reservoir between 2 series connected motors.

## 6.4.4 Mounting Connection lines



Position of the device connections: See [chapter 3 “Device description”](#)

- Clean all lines.
  - Do not use cleaning wool.
  - Pickle and flush welded pipes.
- Remove the protective plugs.
- Mount the lines.
  - Comply with the manufacturer's information.
  - Do not use any sealing materials such as hemp, Teflon tape or putty.

## 6.5 Change of the direction of rotation

A change in the direction of rotation is not possible.

## 7 Operation start-up

### 7.1 Safety instructions for start-up

#### DANGER

##### **Hazardous fluids!**

Danger of death when handling hazardous fluids.

1. Comply with the safety data sheets and regulations on handling hazardous fluids.
2. Collect and dispose of hazardous fluids so that no hazards arise for people or the environment.

#### WARNING

##### **Failure of load-carrying parts due to overload!**

Danger of injury from flying parts.

Danger of injury from spurting fluids.

1. Do not operate the device against closed shut-off devices.
2. Do not operate the device in the false direction of rotation.

#### CAUTION

##### **Hot surfaces!**

Burn injury to skin if touched.

1. Wear protective gloves at temperatures  $\geq 48^{\circ}\text{C}$ .

### 7.2 Preparation

- Before starting the system make sure that a sufficient quantity of the operating fluid is extant to avoid dry running.  
Take this into consideration especially with high output volumes.
- Check all fastening screws on the device.

### 7.3 Further operation start-up

- Open existing shut-off elements upstream and downstream of the device.
- Adjust pressure relief valves in the system installed for lowest opening pressure.
- Allow the device start without or with a low pressure load (jog mode).
  - Flow should have developed after 30 s at the latest.

- Run the device for a few minutes depressurised or with low pressure.
- Vent the system at the highest possible point.
- Gradually increase the pressure load up to the desired operating pressure.
- Operate the system for so long until the final operating state is achieved.
- Check the operating data such as:
  - Flow
  - Operating pressure (as close as possible to device)
  - Fluid temperature (as close as possible to device)
  - Device temperature (in particular in the area of the bearing points)
  - ...
- Document the operating data of the initial start-up for later comparison.
- Check the level of the operating medium in the system.
- Check the device for leaks.
- Check all threaded connections for leaks and retighten if necessary.



In order to ensure a constant and reliable function of the device, an initial maintenance of the device is recommended after several hours warm-up time (max. 24 h). Faults can thus be identified at an early stage.



## 8 Removal

### 8.1 Safety instructions for removal

#### DANGER

##### **Hazardous fluids!**

Danger of death when handling hazardous fluids.

1. Comply with the safety data sheets and regulations on handling hazardous fluids.
2. Collect and dispose of hazardous fluids so that no hazards arise for people or the environment.

#### DANGER

##### **Rotating parts!**

Danger of death due to body parts, hair or clothing getting trapped or entangled.

1. Before all work, ensure that existing drives are voltage-free and pressure-free.
2. Securely prevent restarting during all work.

#### WARNING

##### **Unshielded gearwheels!**

Gearwheels can trap and crush fingers and hands.

1. Do not engage gearwheels.

#### WARNING

##### **Failure of load-carrying parts due to overload!**

Danger of injury from flying parts.

Danger of injury from spurting fluids.

1. Depressurise the device and all connection lines before doing any work.
2. Securely prevent the restoration of pressure while working on the device.

#### CAUTION

##### **Hot surfaces!**

Burn injury to skin if touched.

1. At temperatures  $\geq 48^{\circ}\text{C}$  the device must be allowed to cool down first.

## 8.2 Removal

- Depressurise and de-energize the system.
- Close existing shut-off elements upstream and downstream of the device.
- Open existing drain elements and loosen connection lines. Collect and dispose of discharging medium so that no hazard arises for persons or environment.
- Dismantle the device.
- Clean the device.
- Close the device connections and lines to prevent dirt penetration.

## 9 Maintenance

### 9.1 Safety instructions for maintenance

#### DANGER

##### **Hazardous fluids!**

Danger of death when handling hazardous fluids.

1. Comply with the safety data sheets and regulations on handling hazardous fluids.
2. Collect and dispose of hazardous fluids so that no hazards arise for people or the environment.

#### DANGER

##### **Rotating parts!**

Danger of death due to body parts, hair or clothing getting trapped or entangled.

1. Before all work, ensure that existing drives are voltage-free and pressure-free.
2. Securely prevent restarting during all work.

#### WARNING

##### **Failure of load-carrying parts due to overload!**

Danger of injury from flying parts.

Danger of injury from spurting fluids.

1. Depressurise the device and all connection lines before doing any work.
2. Securely prevent the restoration of pressure while working on the device.

#### CAUTION

##### **Hot surfaces!**

Burn injury to skin if touched.

1. At temperatures  $\geq 48^{\circ}\text{C}$  the device must be allowed to cool down first.

## 9.2 Maintenance work



### Checking and documentation of the operating data

Regular checking and documentation of all operating data such as pressure, temperature, current consumption, degree of filter soiling, etc. contributes to early problem detection.

- Perform maintenance according to specification.
- Replace defective and worn components.
- If required, request spare parts lists and assembly drawings from the manufacturer.
- Document the type and scope of the maintenance work along with the operating data.
- Compare the operating data with the values of the first commissioning. Determine the cause in case of major non-compliances (> 10 %).
- Dispose of packing material and used parts in accordance with the local stipulations.



### Barriers and instructions

All barriers and warning signs removed during this must be attached to their original position on completing maintenance and/or repairs.

## 9.3 Maintenance instructions

The following information provides recommendations on maintenance work and maintenance intervals for the device being used.

Depending on the actually occurring loads in operation, the type, scope and interval of the maintenance work can deviate from the recommendations. The equipment builder/operator shall write an obligatory maintenance plan.



Within the framework of preventive maintenance, it is appropriate to replace wear parts before reaching the wear limit.

With corresponding expertise and sufficient equipment, the replacement can be carried out by the equipment builder/operator. Please consult the manufacturer about this.



### Warranty

In case of improper implementation, any warranty is voided.

<b>Maintenance recommendations High pressure gear motor</b>			
<b>Interval</b>	<b>Maintenance work</b>	<b>Employees</b>	<b>Duration approx. [h]</b>
<b>Firstly: after max. 24 h</b>	Inspection: Flow	1	1
	Inspection: Operating pressure		
	Inspection: Fluid temperature		
	Inspection: Device temperature		
	Inspection: Condition of operating fluid		
<b>Daily</b>	Audiometric monitoring: Unusual noise	1	0.1
	Cleaning: Remove dust deposits and dirt with a moist cloth		
	Visual inspection: Leakages		
<b>3000 Operating hours</b>	Inspection: Flow	1	1
	Inspection: Operating pressure		
	Inspection: Fluid temperature		
	Inspection: Device temperature		
	Inspection: Condition of operating fluid		
<b>6000 Operating hours</b>	Visual inspection: Condition of housing parts	1	0.5
	Visual inspection: Condition of shaft seal		
	Visual inspection: Condition of outboard bearings (if existing)		
<b>As required</b>	Replace: Outboard bearing (if existing)	1	2
	Replace: Shaft seal (only possible with assembly jig)		
	Replace: Other seals		

## 10 Repairs

### 10.1 Safety instructions for repair

#### DANGER

##### **Hazardous fluids!**

Danger of death when handling hazardous fluids.

1. Comply with the safety data sheets and regulations on handling hazardous fluids.
2. Collect and dispose of hazardous fluids so that no hazards arise for people or the environment.

#### DANGER

##### **Rotating parts!**

Danger of death due to body parts, hair or clothing getting trapped or entangled.

1. Before all work, ensure that existing drives are voltage-free and pressure-free.
2. Securely prevent restarting during all work.

#### WARNING

##### **Failure of load-carrying parts due to overload!**

Danger of injury from flying parts.

Danger of injury from spurting fluids.

1. Depressurise the device and all connection lines before doing any work.
2. Securely prevent the restoration of pressure while working on the device.

#### CAUTION

##### **Hot surfaces!**

Burn injury to skin if touched.

1. At temperatures  $\geq 48^{\circ}\text{C}$  the device must be allowed to cool down first.

## 10.2 General

### The repairs covers:

1. Troubleshooting  
Determination of damage, pinpointing and localisation of the damage cause.
2. Elimination of damage  
Elimination of the primary causes and replacement or repair of defective components. The repair is generally made by the manufacturer.

### Repairs by manufacturer

- Before returning the device, fill in the *return notification* form. The form can be filled in online and is available as a pdf file download.



#### Device contains hazardous material

If the device was operated with dangerous liquids, it must be cleaned before the return. If this should not be possible, the safety data sheet of the hazardous material is to be provided beforehand.

### Repair by equipment builder/operator

If corresponding expertise and sufficient equipment is available, the equipment builder/operator can also make the repairs. Please consult the manufacturer about this.

- If required, request spare parts lists and assembly drawings from the manufacturer.
- Use spare parts approved by the manufacturer only.
- Dispose of packing material and used parts in accordance with the local stipulations.



#### Warranty

In case of improper implementation, any warranty is voided.



#### Barriers and instructions

All barriers and warning signs removed during this must be attached to their original position on completing maintenance and/or repairs.

## 10.3 Detecting and eliminating failures

Failure		Potential causes	Possible measures
1.1	<b>Increased noise</b> <i>Cavitation of the motor</i>	Foreign bodies in the feed line/ drain line	Clean feed line/drain line
		Fluid temperature too low	Adjust the temperature of me- dium
1.2	<b>Increased noise</b> <i>Mechanical vibrations</i>	Incorrectly aligned and/or loose coupling	Correct the alignment of the coupling and secure the cou- pling halves
		Incorrectly and/or insufficient line fastening	Fixate lines with suitable fas- tening material (e.g. pipe clamps)
		Wobbling pressure relief valve (if existing)	Increase valve opening pres- sure
		Not a noise-reducing setup	Use dampers
		Adverse installation location	Check installation location
		Wear/Tooth flank worn out	Replace the device
2	<b>Unit does not start</b>	Wrong direction of rotation	Correct the direction of rota- tion
		Minimum filling level in the sup- ply tank undercut	Top up medium
		Closed/throttled blocking ele- ment in the feed line/drain line	Open the shut-off element
		Foreign bodies in the feed line/ drain line	Clean feed line/drain line
3	<b>Insufficient pressure</b> <b>Insufficient flow rate</b>	Motor speed too Low	Check the unit design Check the design of the feed line/drain line
		Too low viscosity	Check the system design
		Closed/throttled blocking ele- ment in the feed line/drain line	Open the shut-off element
		Foreign bodies in the feed line/ drain line	Clean feed line/drain line
		Wear/Tooth flank worn out	Replace the device
4	<b>Excessive operating tem- perature</b>	Cooling and heat dissipation insufficient	Increase the cooling capacity
		Not sufficient medium in the system	Check the container layout
		Excess fluid is being delivered into the supply tank via pres- sure relief valve under load	Check the unit design



Failure		Potential causes	Possible measures
5	<b>Impermissible unit temperature rise</b>	Pressure too high in association with a media viscosity that is too low	Check the system design
		Suction pressure too high	Reduce the pressure
		Excess fluid is being delivered into the supply tank via pressure relief valve under load	Check the unit design
		Wear	Replace the device
6	<b>Leakages</b> <i>Seal failure</i>	Poor maintenance	Comply with maintenance plan Replace seals
		Mechanical damage	Replace seals
		Thermal overload	Check the operating datas Replace seals
		Pressure too high	Check the operating datas Replace seals
		Gas content in medium too high	Check the operating datas Replace seals
		Corrosion/chemical impact	Check the material compatibility Replace seals
		Wrong direction of rotation	Correct the direction of rotation Replace seals
		Contaminated medium	Provide filtration Replace seals
		Loose threaded connections	Retighten or replace threaded connections
7.1	<b>Coupling</b> <i>Coupling wear</i>	Alignment error	Correct the alignment of the coupling and secure the coupling halves
		Spider overloaded	Check the operating datas Use harder spider
7.2	<b>Coupling</b> <i>Cam break</i>	Spider wear Torque transmission due to metal contact	Adapt maintenance intervals Replace coupling

Failure		Potential causes	Possible measures
7.3	<b>Coupling</b> <i>Premature spider wear</i>	Alignment error	Correct the alignment of the coupling and secure the coupling halves Replace spider
		Spider failure due to chemical corrosion	Check the material compatibility Replace spider
<b>Consult the manufacturer for all unidentifiable failures.</b>			