

# Proportional 3/2 Throttle Cartridge, Size 5

$Q_{\max} = 40 \text{ l/min (10 gpm)}$ ,  $p_{\max} = 250 \text{ bar (3600 psi)}$

Sliding-spool design, direct acting

Series MDT32...MB...-5

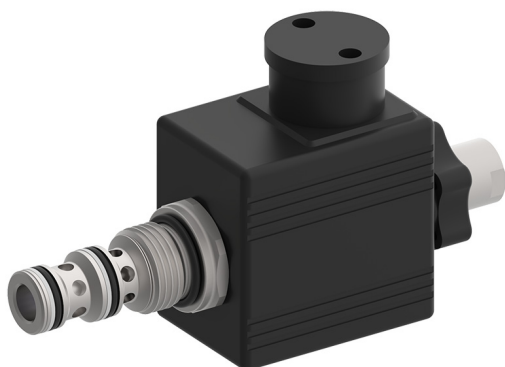

- De-energized closed 1 to 2
- Compact construction for cavity type AM – 3/4-16 UNF
- Operated by a proportional solenoid
- Optional with two emergency manual flow settings
- Reliable operation over the whole pressure and flow range (even with high pressure differentials)
- All exposed parts with zinc-nickel plating
- High pressure wet-armature solenoids
- The slip-on coil can be rotated, and it can be replaced without opening the hydraulic envelope
- Various plug-connector systems and voltages are available
- Can be fitted in a line-mounting body

## 1 Description

Series MDT32...MB...-5 direct acting proportional 3/2 throttle valves are size 5, high performance screw-in cartridges with a 3/4-16 UNF mounting thread. They are designed on the proven sliding-spool principle. The straightforward design delivers an outstanding price/performance ratio. In design "S", in the initial position (de-energized), port 1 is closed and ports 2 to 3 are connected with the full flow rating. In control mode, the flow through the connection 1 to 2 can be regulated proportionally to the control current, but not the closing of connection 2 to 3. Design "T", in the initial position (de-energized) is also closed at port 1, and ports 2 to 3 are connected, but are only used for unloading (see performance graphs). These cartridges are particu-

larly suitable for precise and controlled lifting and lowering movements, but they can also be used for reliable operation in mobile and industrial applications featuring large pressure differences. Optionally, the valves are available with a push-button emergency operation or an emergency manual flow setting via tool wrench. All external parts of the cartridge are zinc-nickel plated according to DIN EN ISO 19 598 and are thus suitable for use in the harshest operating environments. The slip-on coils can be replaced without opening the hydraulic envelope and can be positioned at any angle through 360°. For self-assembly, please refer to the section related data sheets.

## 2 Symbol

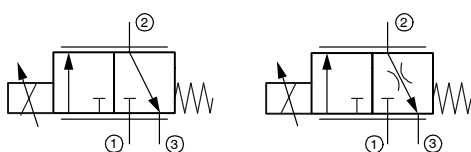

MDT32GS...-5...

MDT32GT...-5...

## 3 Technical data

General characteristics	Description, value, unit
Designation	proportional 3/2 throttle cartridge
Design	sliding-spool design, direct acting
Mounting method	screw-in cartridge 3/4-16 UNF
Tightening torque	40 Nm ± 10 % (30 ft-lbs ± 10 %)

General characteristics	Description, value, unit
Size	nominal size 5, cavity type AM
Weight	0.40 kg (0.9 lbs)
Mounting attitude	unrestricted (preferably vertical, coil down)
Ambient temperature range	-25 °C ... +60 °C (-13 °F ... +140 °F)
MTTF <sub>D</sub> values	150 years, see data sheet 400-P-010101-en
Hydraulic characteristics	Description, value, unit
Maximum operating pressure	250 bar (3600 psi)
Maximum flow rate	- MDT32GT... 40 l/min (10 gpm) - MDT32GS... 30 l/min (7.5 gpm)
Nominal flow rate 1 → 2	- MDT32GT... 28 l/min (7 gpm) at Δp = 10 bar (140 psi) - MDT32GS... 25 l/min (6.5 gpm) at Δp = 10 bar (140 psi)
Volume flow rate 2 → 3	see symbols not proportionally controllable
Leakage flow rate	< 250 cm <sup>3</sup> /min (with p <sub>N</sub> 250 bar) with oil viscosity 33 mm <sup>2</sup> /s (cSt)
Flow direction	see performance graphs control possible only for connection 1 to 2
Hydraulic fluid	HL and HLP mineral oil to DIN 51 524; for other fluids, please contact BUCHER
Hydraulic fluid temperature range	-25 °C ... +70 °C (-13 °F ... +185 °F)
Viscosity range	15...380 mm <sup>2</sup> /s (cSt), recommended 20...130 mm <sup>2</sup> /s (cSt)
Minimum fluid cleanliness Cleanliness class to ISO 4406 : 1999	class 18/16/13
Electrical characteristics	Description, value, unit
Supply voltage	12 V DC, 24 V DC
Control current	12 V = 0...1600 mA, 24 V = 0...800 mA
Power consumption at max. control current	max. 17.5 W
Coil resistance R	- cold value at 20 °C 12 V = 4.35 Ω / 24 V = 17.2 Ω - max. warm value 12 V = 6.8 Ω / 24 V = 26.9 Ω
Recommended PWM frequency (dither)	150 Hz
Hysteresis with PWM	2...5 % I <sub>N</sub>
Reversal error with PWM	2...5 % I <sub>N</sub>
Sensitivity with PWM	< 2 % I <sub>N</sub>
Reproducibility with PWM	< 3 % p <sub>N</sub>
Relative duty cycle	100 %
Protection class to ISO 20 653 / EN 60 529	IP 65 / IP 67 / IP 69K, see "Ordering code" (with appropriate mating connector and proper fitting and sealing)
Electrical connection	DIN EN 175301-803, 3-pin 2 P+E (standard) for other connectors, see "Ordering code"

## 4 Performance graphs measured with oil viscosity 33 mm<sup>2</sup>/s (cSt)

$\Delta p = f(Q)$  Pressure drop - Flow rate characteristic  
[MDT32GT]

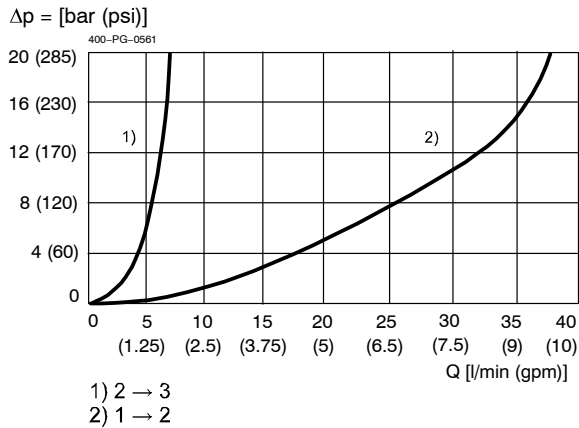

$\Delta p = f(Q)$  Pressure drop - Flow rate characteristic  
[MDT32GS]

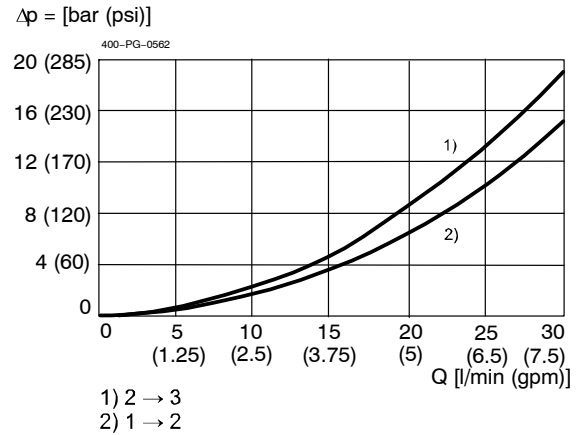

$Q = f(I; \Delta p)$  Flow rate adjustment characteristic  
[MDT32GT]  
1 → 2 with compensator 1)

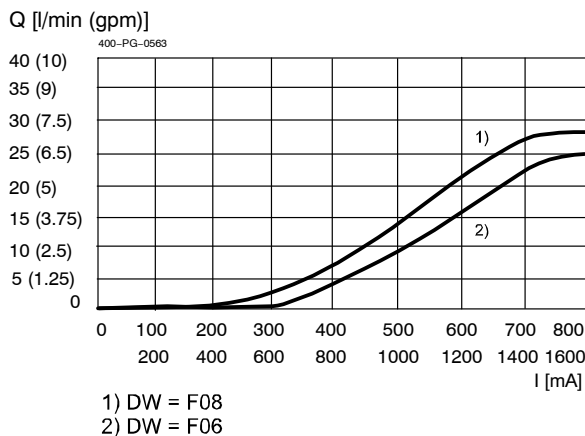

$Q = f(I; \Delta p)$  Flow rate adjustment characteristic  
[MDT32GS]  
1 → 2 with compensator 1)

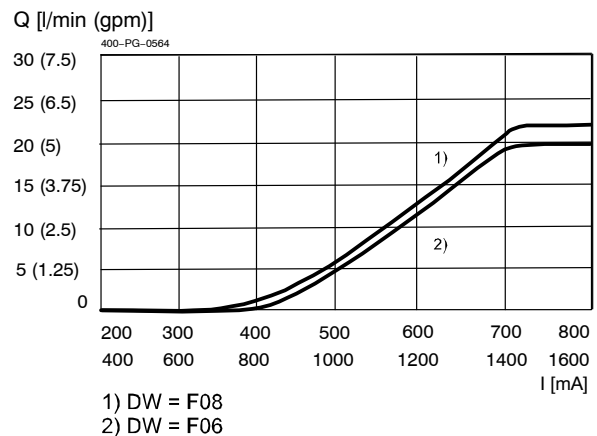

### IMPORTANT!

1) Performance graphs measured with compensator model DWDPB-5D-10-F0\_-1

$Q = f(I; \Delta p)$  Flow rate adjustment characteristic  
[MDT32GT]  
1 → 2 with constant pressure drop

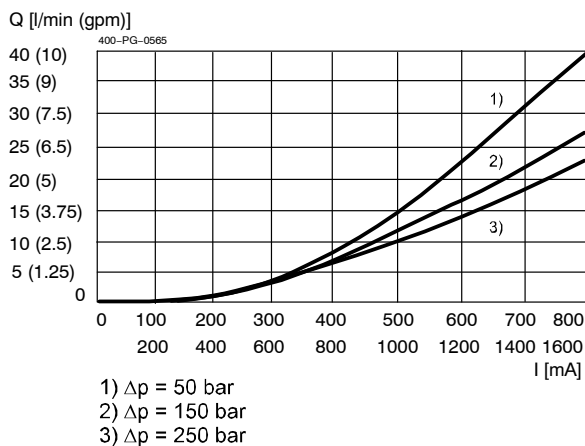

$Q = f(I; \Delta p)$  Flow rate adjustment characteristic  
[MDT32GS]  
1 → 2 with constant pressure drop

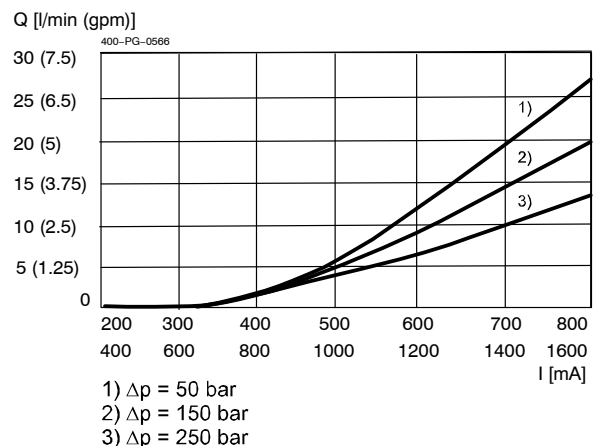

Q = f (Δp; I) Flow rate adjustment characteristic  
[MDT32GT]

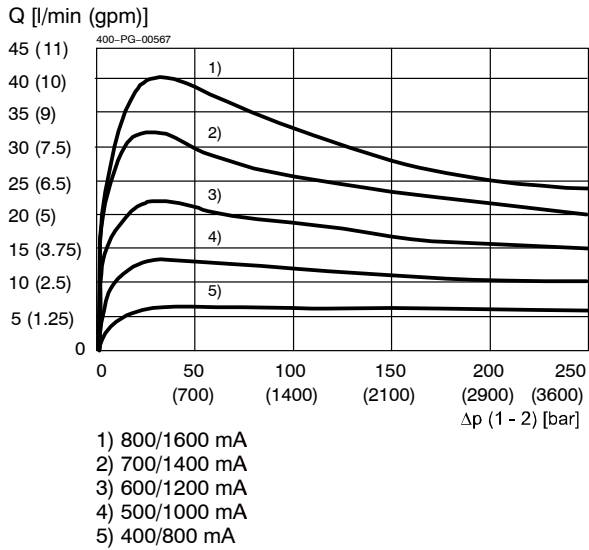

Q = f (Δp; I) Flow rate adjustment characteristic  
[MDT32GS]

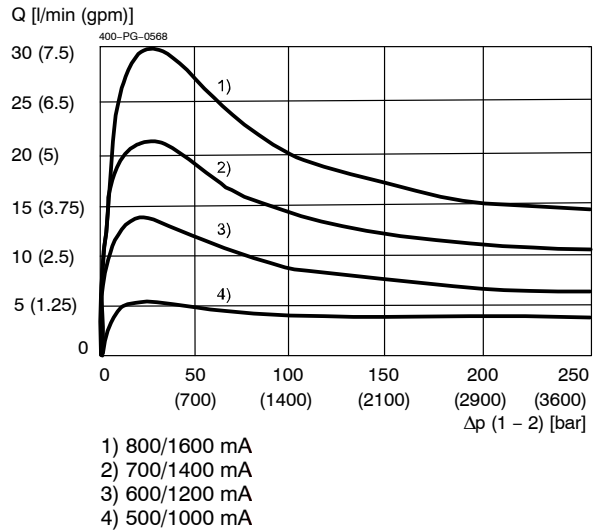

Q = f (Δp; I) Flow rate adjustment characteristic  
[MDT32GT]  
1 → 2 with compensator 2)

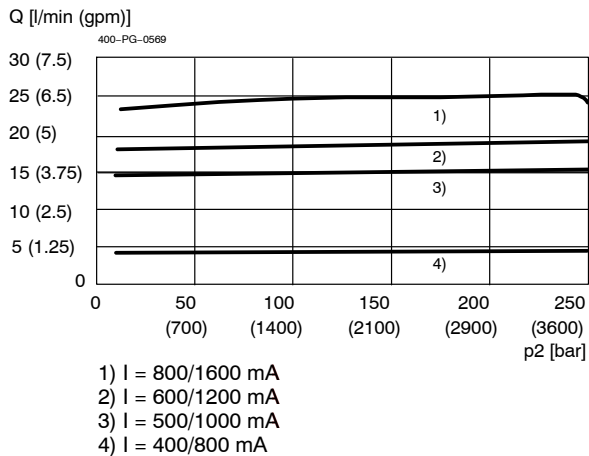

Q = f (Δp; I) Flow rate adjustment characteristic  
[MDT32GT]  
1 → 2 with compensator 2)

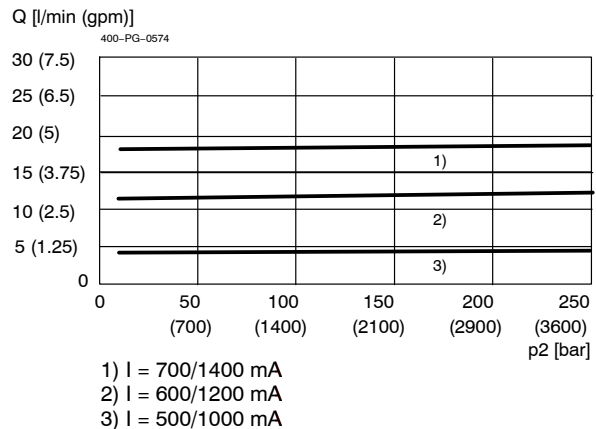

**IMPORTANT!**

2) Performance graphs measured with compensator model DWDPB-5D-10-F06

## 5 Installation information



**IMPORTANT!**

To achieve the maximum performance rating, fit the solenoid coil as shown (with the plug pins at the bottom) and install the valve in a steel body. When fitting the cartridges, note the mounting attitude (preferably vertical, with coil down → automatic air bleed) and use the specified tightening torque. No adjustments are necessary, since the cartridges are set in the factory.



**ATTENTION!**

Only qualified personnel with mechanical skills may carry out any maintenance work. Generally, the only work that should ever be undertaken is to check, and possibly replace, the seals. When changing seals, oil or grease the new seals thoroughly before fitting them.

## 6 Dimensions & sectional view

### 6.1 Standard without emergency operation options "O" and "S"

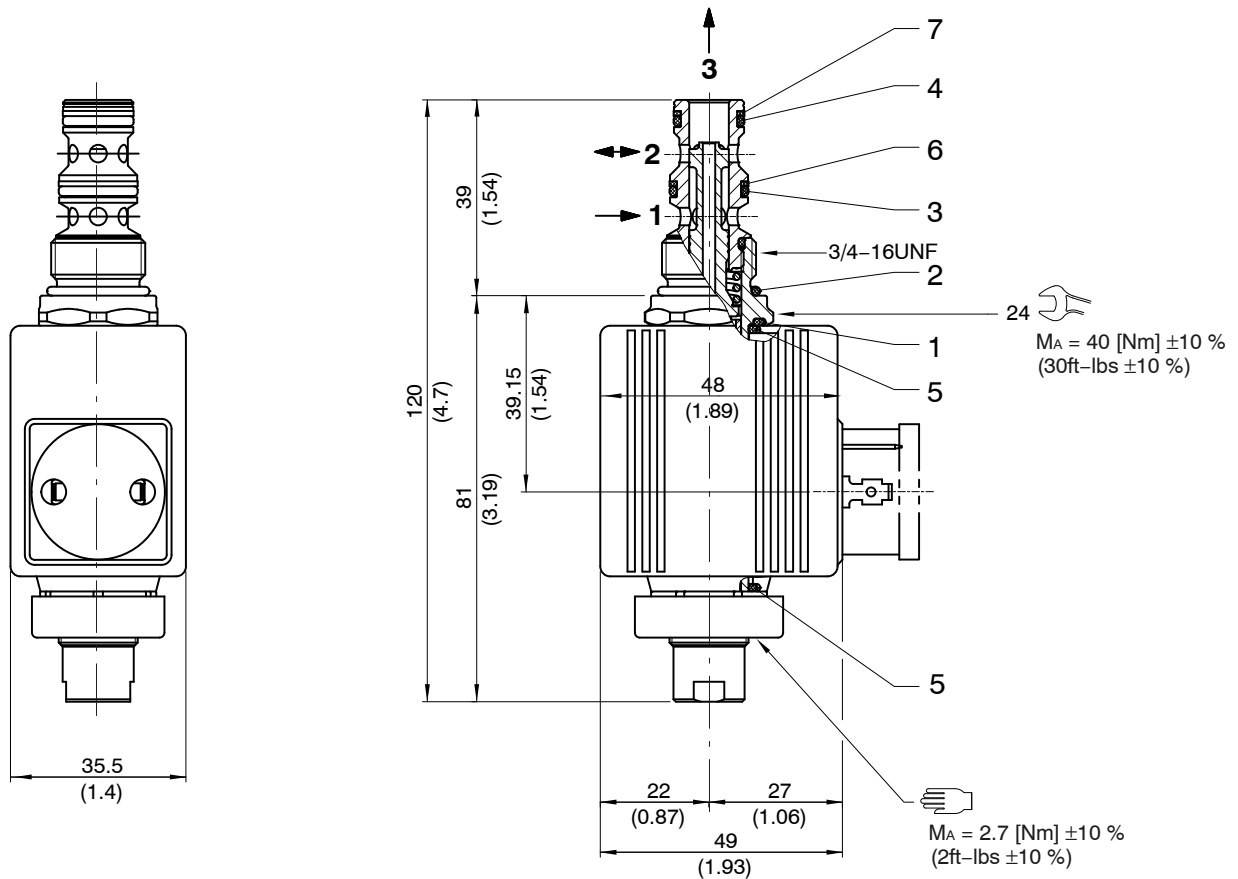

### 6.2 Option with emergency override pin "P" and option with emergency override "S"

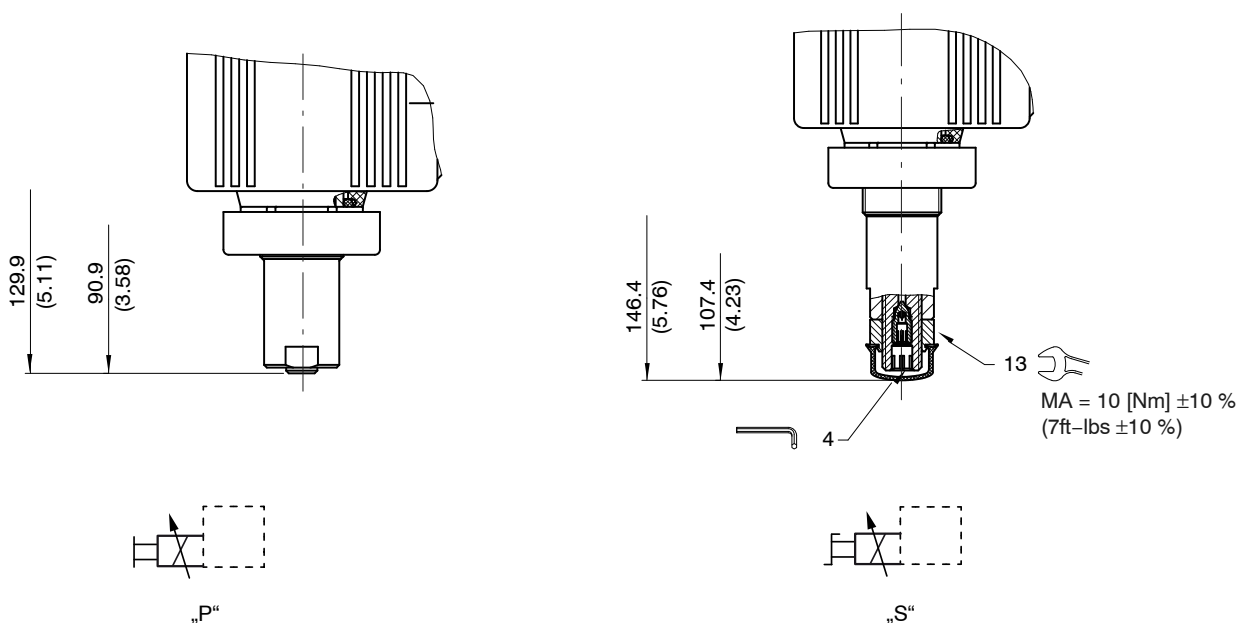

### Seal kit NBR no. DS-247-N <sup>3)</sup>

Item	Qty.	Description
1	1	O-ring $\varnothing$ 18,00 x 2,00 FKM
2	1	O-ring no. 017 $\varnothing$ 17,17 x 1,78 N90
3	1	O-ring no. 014 $\varnothing$ 12,42 x 1,78 N90
4	1	O-ring no. 013 $\varnothing$ 10,82 x 1,78 N90
5	2	O-ring $\varnothing$ 16,00 x 2,00 FKM
6	1	Backup ring $\varnothing$ 10.70 x 1.45 x 1.40 FI0751
7	1	Backup ring $\varnothing$ 09.40 x 1.45 x 1.00 FI0751



### IMPORTANT!

<sup>3)</sup> Seal kit with FKM (Viton) seals no. DS-247-V

### Air-bleeding for option "O" and "P"

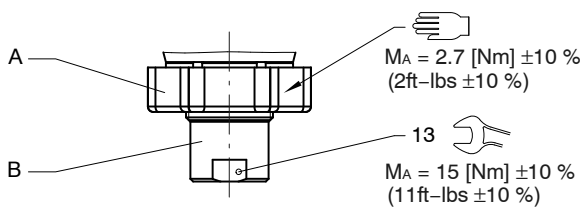

#### Air-bleeding

If necessary, air can be purged from these proportional throttle cartridges by using the cap nut (Item B). The procedure is as follows:

A Knurled nut

B Cap nut

Steps:

1. Reduce pressure in port 3.
2. Slacken and remove the knurled nut.
3. Slacken the cap nut approx. 1.5 turns.

**Caution:**

**Slackening the cap nut allows oil to spray out!**

4. Switch the proportional throttle cartridge ON/OFF several times until no more air bubbles escape.
5. Tighten the cap nut.
6. Refit the knurled nut and tighten it.

### Air-bleeding for option "S"

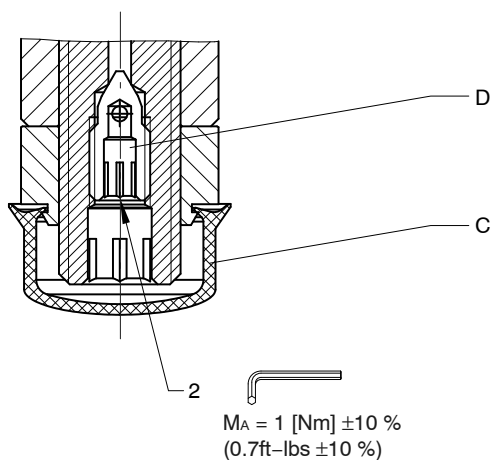

#### Integral air-bleeding

If necessary, air can be purged from these proportional throttle cartridges by using the integral air-bleed screw (Item D). The procedure is as follows:

C Protective cap

D Air-bleed screw

Steps:

1. Reduce pressure in port 3.
2. Remove the protective cap.
3. Slacken the air-bleed screw approx. 2 turns.
4. Switch the proportional throttle cartridge ON/OFF several times until no more air bubbles escape.
5. Tighten the air-bleed screw.
6. Fit the protective cap.

## 7 Emergency manual flow setting

Optionally, the proportional throttle cartridges can be supplied with an integral manual flow setting. If a proportional solenoid is faulty, for example, this manual flow setting enables the required flow rate to be set mechanically. This manual flow setting is not designed for adjusting the flow in a dynamic control mode.

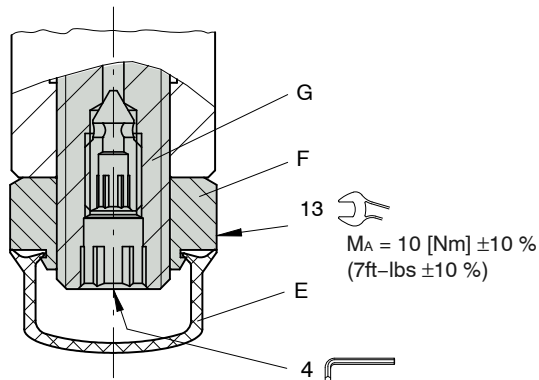

- E Protective cap
- F Lock nut (13 A/F)
- G Adjusting spindle for volume setting

### Setting the flow rate manually

Steps:

1. Remove the protective cap.
2. Slacken the lock nut (13 A/F).
3. Screw in (turn to right) the adjusting spindle (4 A/F) until the required flow rate is set.
4. Tighten the lock nut (13 A/F).
5. Fit the protective cap.

### Restoring the factory settings

Steps:

1. Solenoid de-energised.
2. Remove the protective cap.
3. Slacken the lock nut (13 A/F).
4. Unscrew the adjusting spindle (4 A/F) to its end-stop, then screw it in 2 turns.
5. Tighten the lock nut (13 A/F).
6. Fit the protective cap.

## 8 Application examples

### Symmetric option MDT32GS...-5

Use without compensator:

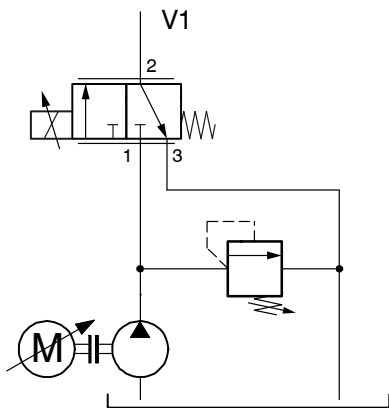

- Full-flow connection 2 → 3
- Control is only available with connection 1 → 2

## Symmetric option MDT32GS...-5

Use with compensator:

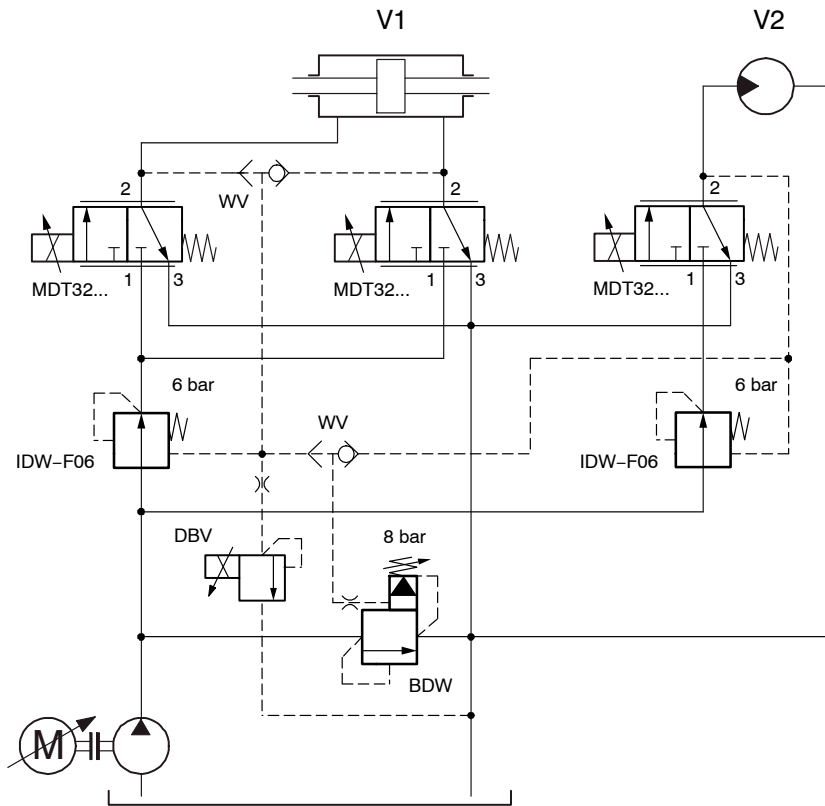

- Full-flow connection 2 → 3
- Control is only available with connection 1 → 2

## Throttled option MDT32GT...-5

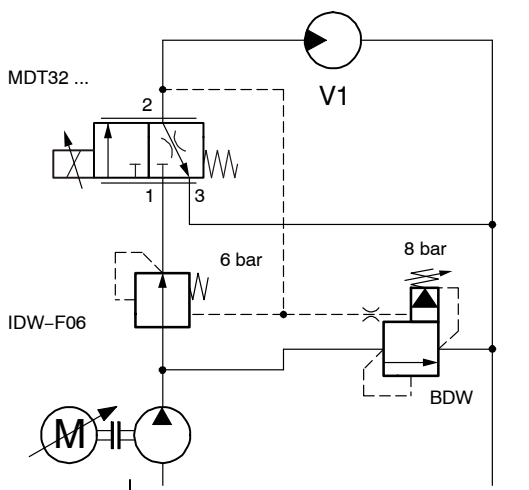

- Connection 2 → 3 is not full-flow (suitable for unloading)
- Control is only available with connection 1 → 2



## 9 Ordering code

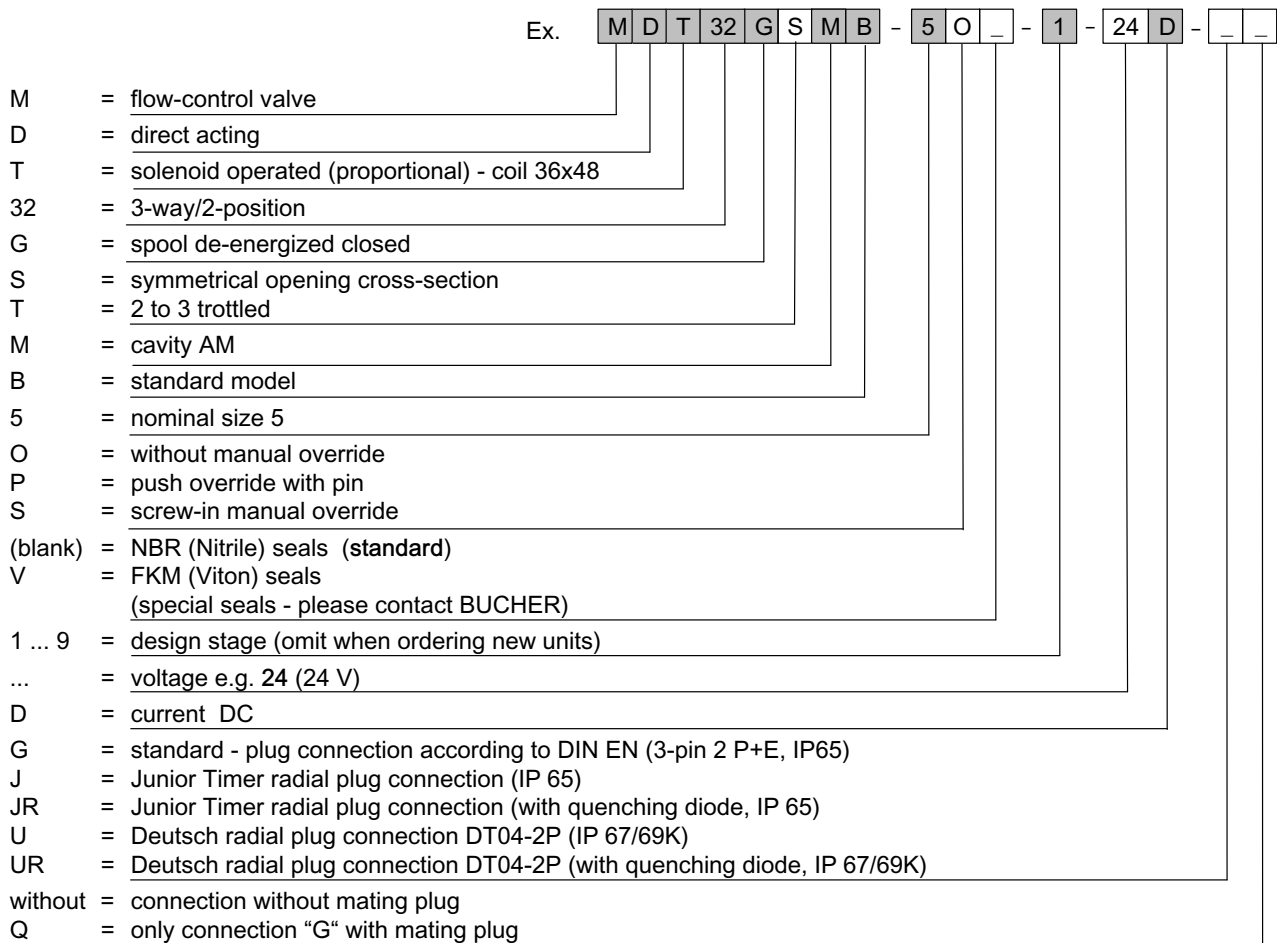

## 10 Related data sheets

Reference	(Old no.)	Description
400-P-040011	(i-32)	The form-tool hire programme
400-P-040181	(i-33.11)	Cavity type AM
400-P-120212	(W-2.141)	Coils for screw-in cartridge valves
400-P-720111	(G-4.20)	Line-mounting body, type GAMA (G 3/8")
400-P-010101		MTTF <sub>D</sub> values for hydraulic valves

info.ch@bucherhydraulics.com

www.bucherhydraulics.com

© 2021 by Bucher Hydraulics AG Frutigen, CH-3714 Frutigen

All rights reserved.

Data is provided for the purpose of product description only, and must not be construed as warranted characteristics in the legal sense. The information does not relieve users from the duty of conducting their own evaluations and tests. Because the products are subject to continual improvement, we reserve the right to amend the product specifications contained in this catalogue.

Classification: 430.310.325.305.310.310