

Check valve

Spring loaded check

$Q_{\max} = 45 \text{ l/min}$, $p_{\max} = 350 \text{ bar}$

plate type

Type series: REVH-3-...



- Screw-in cartridge valve
- Hydraulic pilot-operated
- Virtually leak-proof in closed condition
- High pressure rating

Description

The ERVH series plate-type check valve is characterized by the fact that it can be opened by a hydraulic pilot pressure at X against the no-flow direction and by very high pressure load capacity. The plate-type spring-loaded check valve is very robust, extremely leak proof and dirt resistant. Valve seat, poppet and

body are hardened. The properties of the sealing faces have been enhanced by precision mechanical processing. The valves prevent flow in the screw-in direction (B to A) and open in the opposite direction. The valve is available in nominal sizes 1, 2, 3, 4 and 5.

Symbol

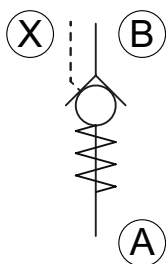

Technical Data

General Characteristics	Description, value, unit
Function group	Check valve
Function	Spring loaded check
Design	Screw-in cartridge valve
Characteristic	plate type
Construction size	nominal size 3
Thread size	G 1/2"
Mounting attitude	unrestricted
Weight	0,07 kg
Tightening torque steel	40 Nm

Hydraulic Characteristics	Description, value, unit
Maximum operating pressure	350 bar
Maximum flow rate	45 l/min
Nominal flow rate	30 l/min
Flow direction	see symbol
Hydraulic fluid	HL and HLP mineral oil according to DIN 51 524; other fluids on request!
Minimum fluid temperature	- 30 °C
Maximum fluid temperature	+ 80 °C
Viscosity range	10 ... 500 mm ² /s (cSt)
Minimum fluid cleanliness (cleanliness class according to ISO 4406:1999)	class 20/18/15
Geometric Differential Area Ratio	1:3
Opening pressure	1.0 bar

i NOTE!
For other values please contact Bucher Hydraulics.

Performance graphs

measured with oil viscosity 33.0 mm²/s (cSt)

$\Delta p = f(Q)$ Pressure drop-flow rate characteristic

Δp [bar]

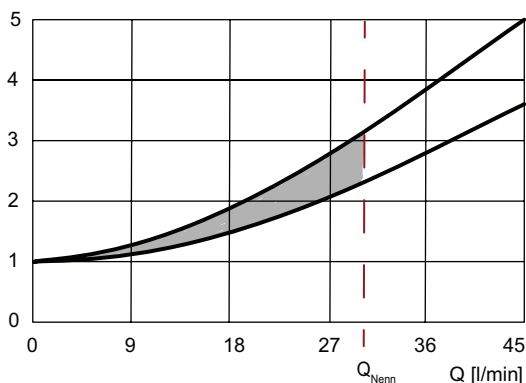

Calculation of pilot pressure

$$\text{Pilot pressure} = \frac{\text{load pressure A} - \text{back pressure B}}{\text{opening area ratio } i} + 3 + \text{back pressure B}$$

Dimensions and sectional view

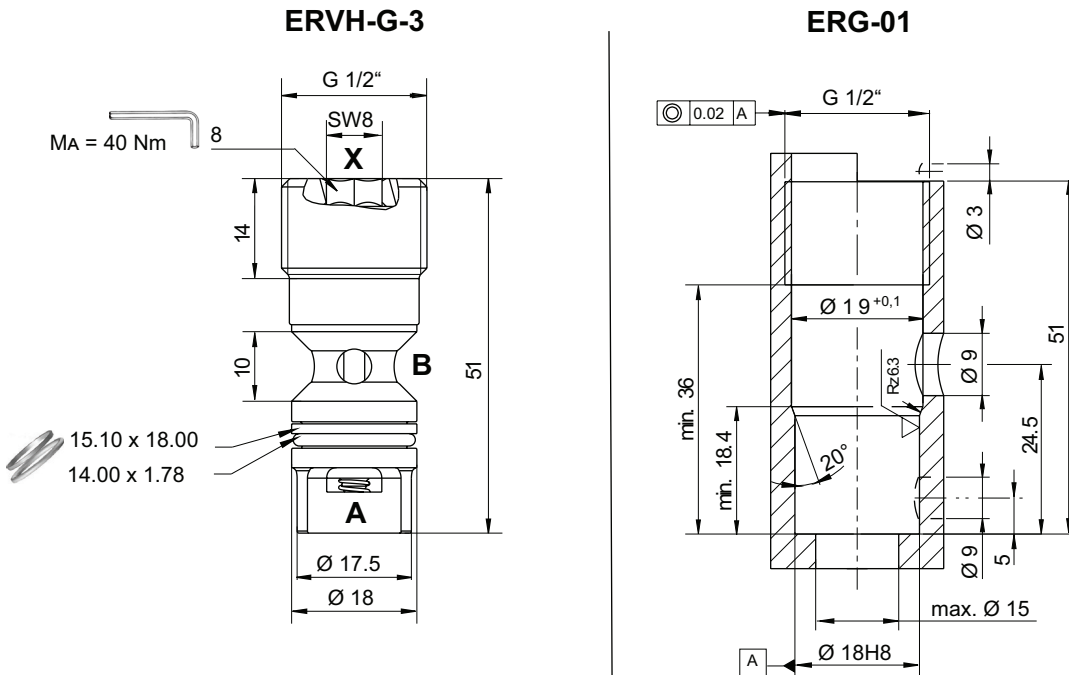

ERVH-G-3 = check valve / screw-in cartridge valve

ERG-01 = dimension of the cavity for screw-in cartridge valve ERVH-G-3
The dimensions specified apply to the mounted state.

Installation information

NOTE! When fitting the screw-in cartridge valve, use the specified tightening torque. The value can be found in the chapter technical data. Orifices or nozzles are to be placed after the check valve. If this is not possible, a right-angled bore must be designated between the check valve and the nozzle. (see data sheet 170-P-059000).

ATTENTION! When fitting the valve, make sure that it is firmly seated on the sealing surface and that it is not deformed by the use of excessive force.

Application Notes

NOTE! The maximum operating pressure must not be exceeded even when pressure peaks occur. In applications such as accumulator circuits, where sudden pressure can be applied to the valve in the free-flow direction, ensure that the specified flow ratings are not exceeded. Buyers bear the sole responsibility for ensuring that the valve is suitable for their applications and must be substantiated by trials or testing, if necessary.

ATTENTION! The valves are only suitable for pressure relief in the opening direction to a limited extent. (if necessary, please consult Bucher Hydraulics).

Ordering code

ERVH - G - 3 -

ERVH = hydraulic pilot-operated check valve, screw-in type

G = whitworth pipe thread G1/2"

3 = nominal size 3, Q_{Nominal} 30 l/min

blank = NBR (Nitrile) seal (standard) *(Item no.: 170629753)*

V = FKM (Viton) seal *(Item no.: 170529753)*

Related data sheets

Reference	Description
170-P-059000	Using nozzles or orifices before a Check Valve