

serv-Clip® -1 for mounting on pressurized pipes

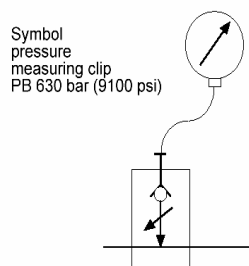
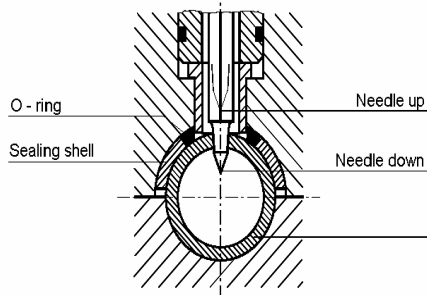
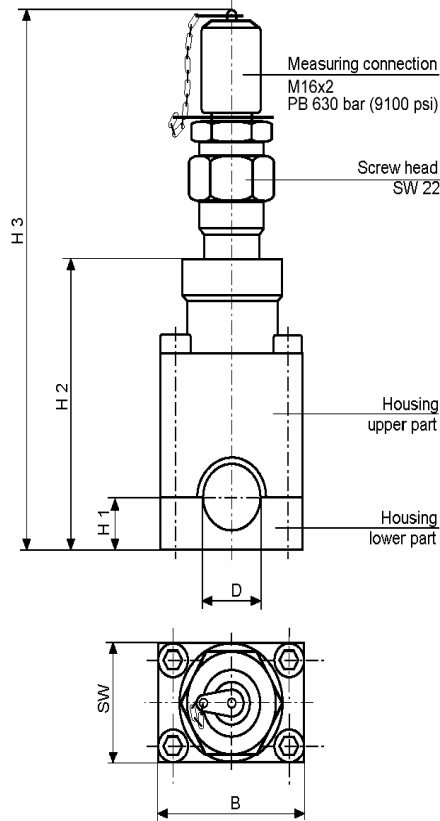

- ◆ Quick and cheap installation of a measuring point
- ◆ Pressure measurement when there is no connection
- ◆ Particle measurement according to ISO or NAS classes
- ◆ No longer necessary to cut open tubes
- ◆ Measurement on hydraulic plants without switching off
- ◆ For use up to 630 bar (9100 psi) working pressure
- ◆ For pipe wall thickness up to 5 mm
- ◆ Installation time for **serv-Clip** only takes a few minutes
- ◆ **serv-Clip** is registered trade mark of BKM Hagen / Germany

Description

The patented pressure measuring clip is simply screwed onto the cleaned surface of the pressurised hydraulic tube. It is not necessary to interrupt the operation of the plant.

A specially shaped steel needle is inserted through the wall of the tube above the screw head.

The screw head is then screwed back. The created hole is then open and it is possible to measure the pressure immediately.

This connection is simple, quick and safe to install. The procedure only takes a few minutes. No special tools are required to install the serv-Clip. The system is completely leakproof. Any pollution of the hydraulic liquid is impossible.

It is not necessary to dismantle the measuring clip on completion of the measuring procedure in order to save costs. The operational safety of the hydraulic system is maintained. The measuring point remains permanently available for taking measurements.

Materials

Housing	9SMnPb28k	Sealing shell	St 37.4
O-ring	Viton	Screw head	9SMnPb28k
Measuring-needle	58CrV4		

Dimensions

D tube	type mm (A)	H1	H2	H3	B	SW
10 - L + S	SC-1-A-10	15	69	128	40	30
12 - L + S	SC-1-A-12	15	70	129	40	30
14 - S	SC-1-A-14	15	71	130	40	30
15 - L	SC-1-A-15	15	71,5	130,5	40	30
16 - S	SC-1-A-16	15	72	131	40	30
18 - L	SC-1-A-18	15	73	132	40	30
20 - S	SC-1-A-20	20	74	133	50	30
22 - L	SC-1-A-22	20	75	134	50	30
25 - S	SC-1-A-25	20	76,5	135,5	50	30
28 - L	SC-1-A-28	20	78	137	50	30
30 - S	SC-1-A-30	30	79	148	65	30
35 - L	SC-1-A-35	30	81,5	140,5	65	30
38 - S	SC-1-A-38	30	83	142	65	30
42 - L	SC-1-A-42	30	85	144	65	30
D tube	type Tube (T)	H1	H2	H3	B	SW
3/8"	SC-1-T-3/8	15	69	128	40	30
1/2"	SC-1-T-1/2	15	70	129	40	30
5/8"	SC-1-T-5/8	15	72	131	40	30
3/4"	SC-1-T-3/4	20	78,5	137,5	50	30
1"	SC-1-T-1	20	82	141	50	30
1 1/4"	SC-1-T-1 1/4	30	95	154	65	30
1 1/2"	SC-1-T-1 1/2	30	98	157	65	30

2" Tube in Type 2 available (Page 12)

Other diameters (ID-NB) ins Pipe (P) available:

Type 1 : 1/2", 3/4", 1"

Type 2 : 1/4", 3/8", 1/2", 3/4", 1", 1 1/4", 1 1/2", 2", 2 1/2", 3"



serv-Clip[®] -1 for mounting on pressurized pipes



Characteristics to order

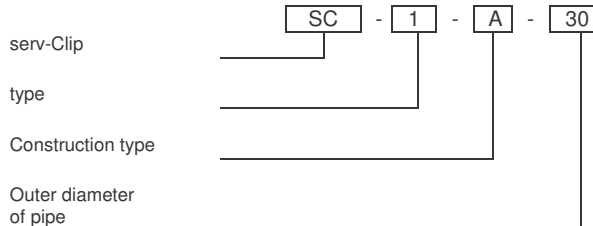

Tube recommendations according to the manufacturer of screwing fittings

Series L	10 x 1,5 / 12 x 1,5	Series S	10 x 3,0 / 12 x 3,5
	15 x 2,0 / 18 x 2,0		14 x 4,0 / 16 x 3,0
	22 x 2,0 / 28 x 2,0		20 x 3,5 / 25 x 4,5
	35 x 2,0 / 42 x 3,0		30 x 4,0 / 38 x 5,0

Safety instructions

To ensure a correct and safe installation of the serv-Clip, please read our separate leaflet 12.B with installation instructions and a chapter on safety referring to pressure measuring clips.

The indicated measuring clips **serv-Clip** are exclusively for use in fluid-technical plants. The field of application is Tubes with technical oils, like hydraulic systems and lubrication oil supply or cooling plants.

Use in air and gas tubes is forbidden.

We reserve ourselves the right to modifications which are useful for any further technical development.

Installation of the serv-Clip

Prior to the installation a check must take place to ensure that the outer diameter of the tube concerned and that of the selected **serv-Clip** match. It is not permitted to install a serv-Clip onto tubes that are seriously rusted or seem to be cracked.

Furthermore, it is a precondition that the tube system should be laid and fixed in such a way that the **serv-Clip** is not affected by any additional burdens, stress and tensions. Tubes are to be laid so as to be adequately stable in relation to the operational conditions and they are to be equipped with fixed points.

Then the part of the tube where the installation is to take place has to be cleaned and all paint and paint remains are to be removed. The tube should be smooth, clean and dry at this point.

Then the housing, consisting of two parts, is positioned on the tube. The four housing screws are now fastened firmly.

The last step is to turn the screw head to the right to the stop position, using a wrench (without extension). The screw head is then screwed back.

Thus the connection has been made and the measuring point can be put to permanent use.

Tolerances of the outer diameter of the tube according to DIN 2391

tube - Ø	permitted deviation
10 mm	3/8" ± 0,10 mm
12 – 30 mm	1/2" : 5/8"; 3/4"; 1" ± 0,08 mm
35 – 38 mm	1 1/4"; 1 1/2" ± 0,15 mm
42 mm	-/- ± 0,20 mm

Tube recommendation for steel made serv-Clips

Seamless drawn steel tubes made out of ST 35.4 material or pre-treated basic material ST 37.4 according to DIN 1630. Condition when supplied NBA (normalizing, bright annealed) with outer tube diameter tolerances according to DIN 2391, maximum hardness: HRB 75. Construction dimensions of the serv-Clip are adapted to the tubes and tolerances according to DIN 2391.

Pressure capacity P_B 630 (9100 psi) the indications with regard to pressure and safety are based on the installation according to this data leaflet



Working temperature Steel -40... +120 °C
 O-ring in Viton -25... + 200 °C
 The indicated temperature limits for sealing materials are guidelines as these temperature limits may be influenced considerably by the medium.

clip material	temperature range	Pressure reduction
Steel	-40... +120 °C	---

Pressure reduction Required pressure reduction due to the material in comparison to catalogue details in the case of increased or reduced temperatures.
 If there are divergent definitions for permissible pressures, safety margins, temperatures and, if necessary, applicable pressure reductions due to standards, regulations or approvals for specific applications, the information provided by them is obligatory. Nominal pressures (P_N) and working pressures (P_E) detailed in the catalogue are max. permissible working pressures including pressures peaks, whereby the temperature limits and pressure reductions detailed in the table above must be taken into consideration.

Functional safety under stationary load

Types with P_N indications : 4 times

Types with P_B indications : 2.5 times

Technical tests Tested sample: **serv-Clip** measuring clip
 Tube diameter: 10... 42 mm / 3/8" ... 1 1/2"
 Installation method: direct installation
 Liquid used in test: Hydraulic oil Aero Shell Fluid 4

High pressure test Stress: Static
 Test pressure: 2400 bar (34800 psi)
 Test result: No damages to the measuring clip could be detected. No leakages of the measuring clip could be detected.

Pulse pressure test Stress: Dynamic
 Test frequency: 1 Hz
 Impulse pressure: 400 bar (5800 psi)
 Cycles: 1 million
 Test result: After completion of this load alteration test neither damages to nor leakages of the measuring clip could be detected.

Flow rate The flow rate measured applies to the series sc-1-A-.....and its value remains the same for all **serv-Clip** sizes ranging from 1042 mm / 3/8" ... 1 1/2", as all types are equipped with the same interior parts and needle diameters.

The flow rate was measured at an oil temperature of 25 °C.

The test medium is the hydraulic oil HLP 46, which means its viscosity is 46 mm²/s at 40 °C.

The measurement was taken by means of a measuring hose of 1 meter lengths featuring a M16x2 mm connection coupling.

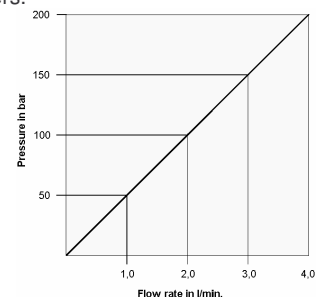

serv-Clip[®] -1 for mounting on pressurized pipes



Installation

1. Place in position

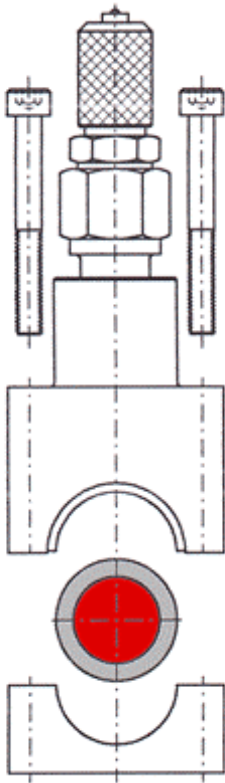

2. Screw down

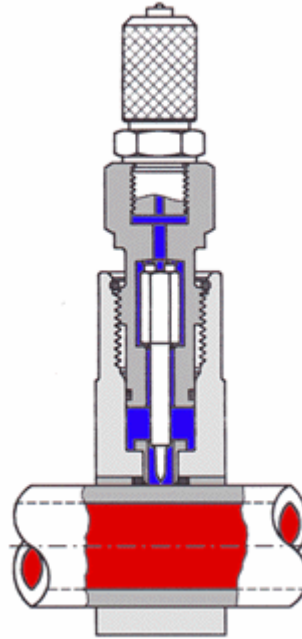

3. Insert

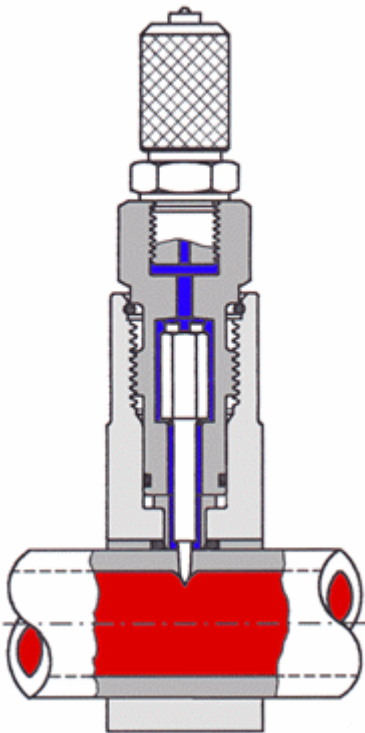

4. Measure

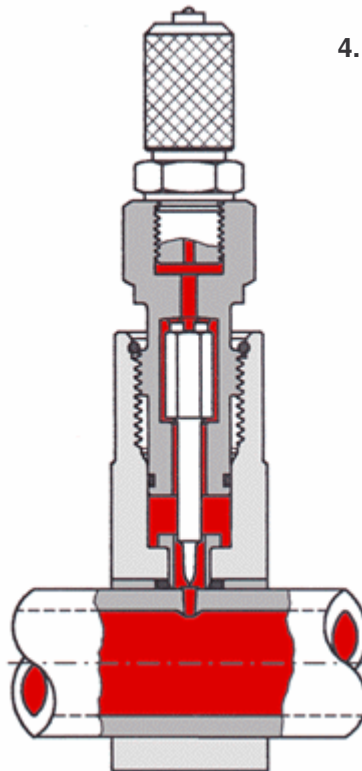

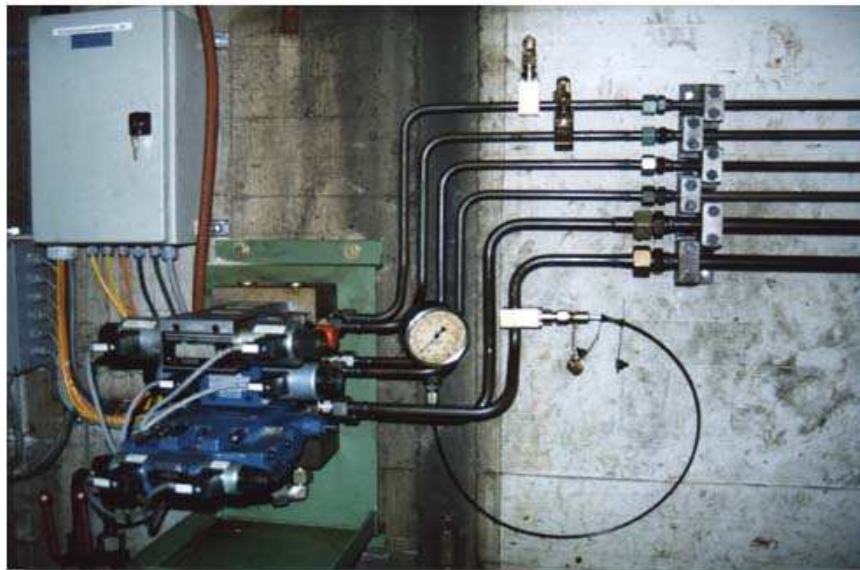

Picture 1: Pressure measurement with **serv-Clip-1** of a servo- hydraulic system



Picture 2: Using **serv-Clip-1** to measure the pressure of a hydraulic cylinder