

# Proportional Pressure-Reducing Cartridge, Size 16

$Q_{\max} = 250 \text{ l/min}$ ,  $p_{\max} = 350 \text{ bar}$   
Seated pilot, spool-type main stage  
Series DRPSB-5B...



- Compact construction for cavity type EB – M42 x 2
- Operated by a proportional solenoid
- 5 pressure ranges available
- External pilot-oil drain
- Excellent stability over the whole pressure and flow range
- All exposed parts with zinc-nickel plating
- High pressure wet-armature solenoids
- The slip-on coil can be rotated, and it can be replaced without opening the hydraulic envelope
- Various plug-connector systems and voltages are available
- Can be fitted in a line-mounting body
- Can be fitted in sandwich bodies

## 1 Description

Series DRPSB-5B... two-stage proportional pressure-reducing valves are size 16, high performance screw-in cartridges with an M42x2 mounting thread. They consist of a spool-type main stage and a leak-free, poppet-type pilot stage. These cartridges reduce the outlet pressure in A proportionally to the control current and independently of the inlet pressure in 2. In the initial position (solenoid de-energized), the connection 2 → 1 is open until the pressure reaches the minimum setting. Five spring ranges are available in order to obtain precise pressure settings over the whole of the required pressure range. To achieve a high de-

gree of functional stability in systems that are susceptible to oscillation, the pilot drain (port 3) must be routed to tank with the least possible back-pressure. These proportional pressure-reducing cartridges are predominantly used in mobile and industrial applications for reducing a system pressure. All external parts of the cartridge are zinc-nickel plated according to DIN EN ISO 19 598 and are thus suitable for use in the harshest operating environments. The slip-on coils can be replaced without opening the hydraulic envelope and can be positioned at any angle through 360°. For self-assembly, please refer to the section related data sheets.

## 2 Symbol

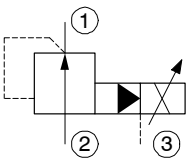

## 3 Technical data

General characteristics	Description, value, unit
Designation	proportional pressure-reducing cartridge
Design	seated pilot, spool-type main stage
Mounting method	screw-in cartridge M42 x 2
Tightening torque	Can be fitted in steel 200 Nm ± 10 % Can be fitted in aluminium 200 Nm ± 10 %
Size	nominal size 16, cavity type EB to ISO 7789-42-06-0-07
Weight	1.25 kg

General characteristics	Description, value, unit
Mounting attitude	unrestricted (preferably vertical, coil down)
Ambient temperature range	-25 °C ... +50 °C

Hydraulic characteristics	Description, value, unit
Maximum operating pressure - ports 1 and 2 - port 3	350 bar no back-pressure
Maximum flow rate	250 l/min
Nominal pressure ranges	40 bar, 100 bar, 160 bar, 250 bar, 350 bar
Pilot-oil consumption	0.1 ... 0.4 l/min
Flow direction	see symbol
Hydraulic fluid	HL and HLP mineral oil to DIN 51 524; for other fluids, please contact BUCHER
Hydraulic fluid temperature range	-25 °C ... +70 °C
Viscosity range	15...380 mm <sup>2</sup> /s (cSt), recommended 20...130 mm <sup>2</sup> /s (cSt)
Minimum fluid cleanliness Cleanliness class to ISO 4406 : 1999	class 18/16/13

Electrical characteristics	Description, value, unit
Supply voltage	12 V DC, 24 V DC
Supply voltage tolerance	± 10 %
Control current	12 V = 0...1400 mA, 24 V = 0...750 mA
Power consumption at max. control current	max. 19 W
Coil resistance R - cold value at 20 °C - max. warm value	12 V = 5.8 Ω / 24 V = 20.9 Ω 12 V = 9.1 Ω / 24 V = 32.7 Ω
Recommended PWM frequency (dither)	200 Hz
Hysteresis with PWM	2...4 % I <sub>N</sub>
Reversal error with PWM	1...3 % I <sub>N</sub>
Sensitivity with PWM	≤ 1 % I <sub>N</sub>
Reproducibility with PWM	< 2 % p <sub>N</sub>
Relative duty cycle	100 %
Protection class to ISO 20 653 / EN 60 529	IP 65 / IP 67 / IP 69K, see "Ordering code" (with appropriate mating connector and proper fitting and sealing)
Electrical connection	DIN EN 175301-803, 3-pin 2 P+E (standard) for other connectors, see "Ordering code"

## 4 Performance graphs

measured with oil viscosity 33 mm<sup>2</sup>/s (cSt)

$p = f(I)$  Pressure adjustment characteristic

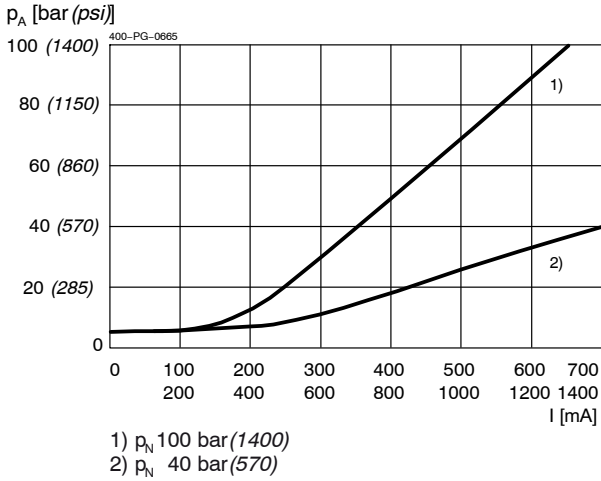

$p = f(I)$  Pressure adjustment characteristic

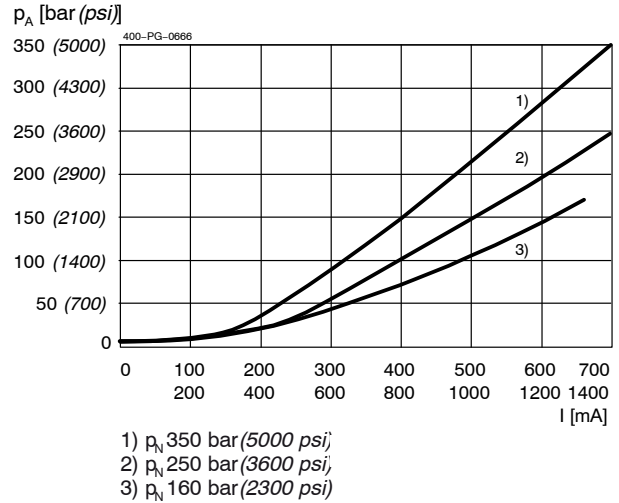

$p = f(Q)$  Pressure - Flow rate characteristic  $p_N = 40$  bar

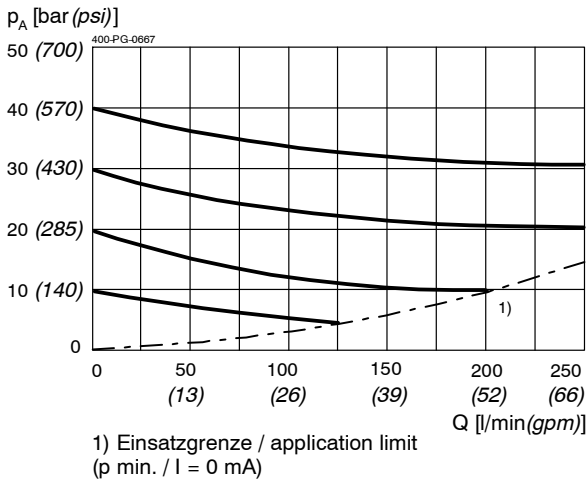

$p = f(Q)$  Pressure - Flow rate characteristic  $p_N = 100$  bar

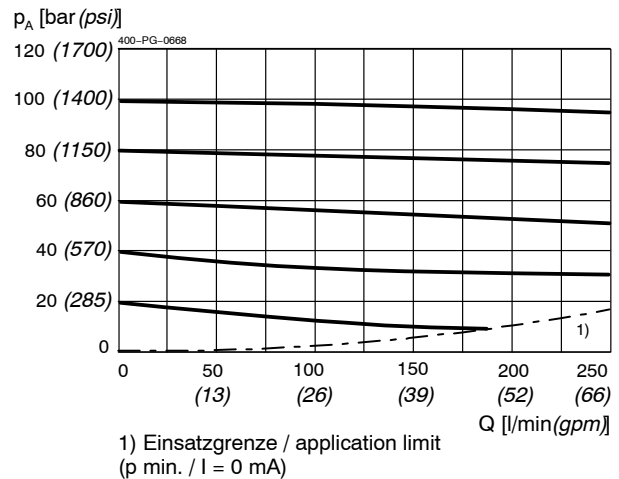

$p = f(Q)$  Pressure - Flow rate characteristic  $p_N = 160$  bar

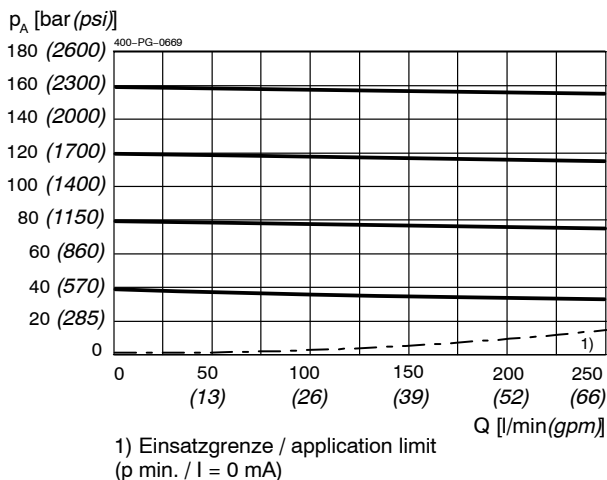

$p = f(Q)$  Pressure - Flow rate characteristic  $p_N = 250$  bar

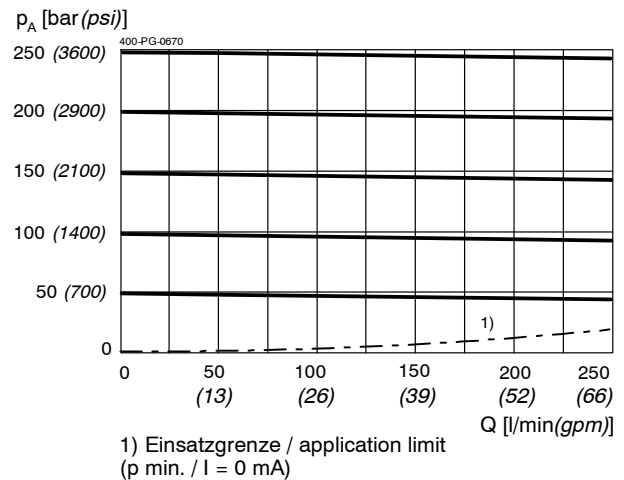

$p = f(Q)$  Pressure - Flow rate characteristic  $p_N = 350 \text{ bar}$

$p_A$  [bar (psi)]

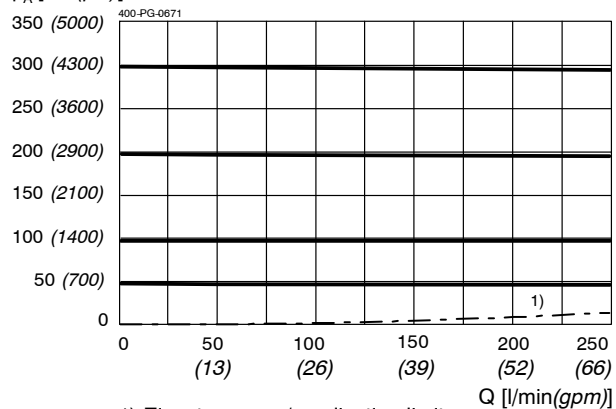

1) Einsatzgrenze / application limit  
( $p_{min.} / I = 0 \text{ mA}$ )

## 5 Dimensions & sectional view

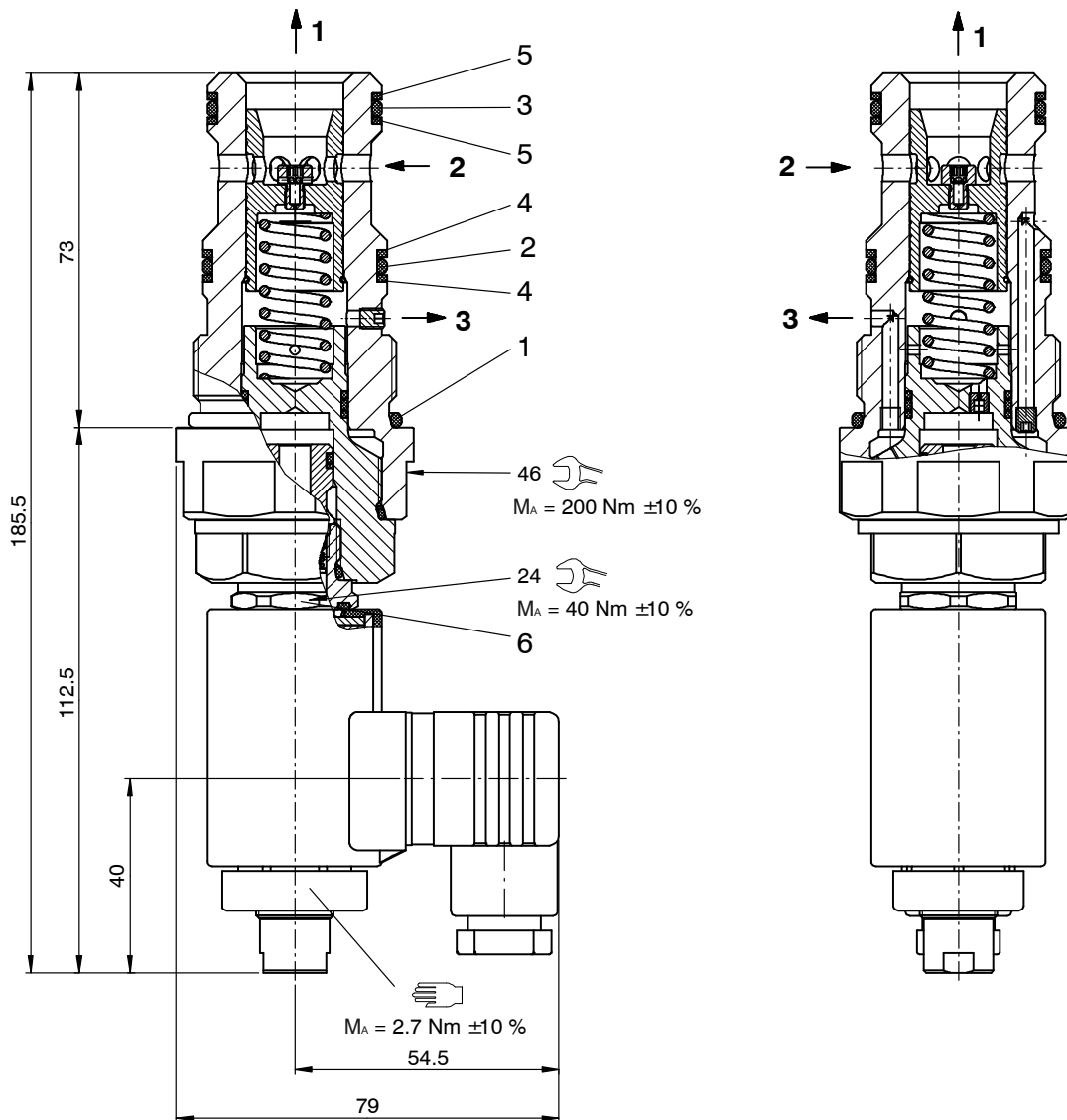

Seal kit NBR no. DS-358-N <sup>1)</sup>

Item	Qty.	Description
1	1	O-ring no. 129 $\varnothing$ 39.34 x 2.62 N90
2	1	O-ring no. 125 $\varnothing$ 32.99 x 2.62 N90
3	1	O-ring no. 124 $\varnothing$ 31.42 x 2.62 N90
4	2	Backup ring $\varnothing$ 32.00 x 2.00 x 1.40 FI0751
5	2	Backup ring $\varnothing$ 30.00 x 2.00 x 1.40 FI0751
6	1	Seal kit NBR no. DS-355-N / seal kit with FKM (Viton) seals no. DS-355-V



### IMPORTANT!

<sup>1)</sup> Seal kit with FKM (Viton) seals no. DS-358-V

### 6 Installation information



#### IMPORTANT!

To achieve the maximum performance rating, fit the solenoid coil as shown (with the plug pins at the bottom) and install the valve in a steel body. When fitting the cartridges, note the mounting attitude (preferably vertical, with coil down → automatic air bleed) and use the specified tightening torque. No adjustments are necessary, since the cartridges are set in the factory.



#### ATTENTION!

To prevent any pressure surges, port 3 must be routed to tank with the least possible back-pressure. Any tank pressure acting at port B is additive to the pressure setting at the main port A.



#### ATTENTION!

Only qualified personnel with mechanical skills may carry out any maintenance work. Generally, the only work that should ever be undertaken is to check, and possibly replace, the seals. When changing seals, oil or grease the new seals thoroughly before fitting them.

### 7 Ordering code

Ex. DRP S B - 5 B - 250 - 16 \_ - 1 24 D \_

- DRP = pressure-reducing cartridge, two stage
- S = standard solenoid (proportional)
- A ... Q = standard model - see relevant data sheets
- Z ... R = special features - please consult BUCHER
- 5 = pressure function 5 (pressure-reducing, external pilot drain)
- D = cavity type EB
- 350 = pressure range ...350 bar
- 250 = pressure range ...250 bar
- 160 = pressure range ...160 bar
- 100 = pressure range ...100 bar
- 040 = pressure range ... 40 bar
- 10 = nominal size 16
- (blank) = NBR (Nitrile) seals (standard)
- V = FKM (Viton) seals  
(special seals - please contact BUCHER)
- 1 ... 9 = design stage (omit when ordering new units)
- ... = voltage e.g. 24 (24 V)
- D = current DC
- (blank) = DIN EN 175301-803 connection with mating plug (standard, IP 65)
- M100 = DIN EN 175301-803 connection without mating plug
- C = Kostal plug connection (IP 65)
- JT = Junior Timer radial plug connection (with protection diode, IP65)
- IT = Junior Timer axial plug connection (with protection diode, IP65)
- D = Deutsch plug connection 45° DT04-2P (IP67/69K)
- DT = Deutsch plug connection 45° DT04-2P (with protection diode, IP67/69K)
- S = AMP Superseal 1.5 (IP67) / Metri-Pack 150 (IP65) plug connection
- F = flying leads (500 mm)

} mating plug not supplied

## 8 Related data sheets

Reference	(Old no.)	Description
400-P-040011	(i-32)	The form-tool hire programme
400-P-080111	(i-55.2)	Cavity type EB
400-P-120110	(W-2.141)	Coils for screw-in cartridge valves series D36
400-P-580101		Pilot valve DVSA-1L
400-P-750115	(G-29.22)	Line- and manifold-mounting body, type GEBAA (G 1")

[info.ch@bucherhydraulics.com](mailto:info.ch@bucherhydraulics.com)

[www.bucherhydraulics.com](http://www.bucherhydraulics.com)

© 2022 by Bucher Hydraulics AG Frutigen, CH-3714 Frutigen

All rights reserved.

Data is provided for the purpose of product description only, and must not be construed as warranted characteristics in the legal sense. The information does not relieve users from the duty of conducting their own evaluations and tests. Because the products are subject to continual improvement, we reserve the right to amend the product specifications contained in this catalogue.

Classification: 430.305.300.305.330.310