

General information

Cavity

Type series: Cavity C0830

Dimensions and sectional view

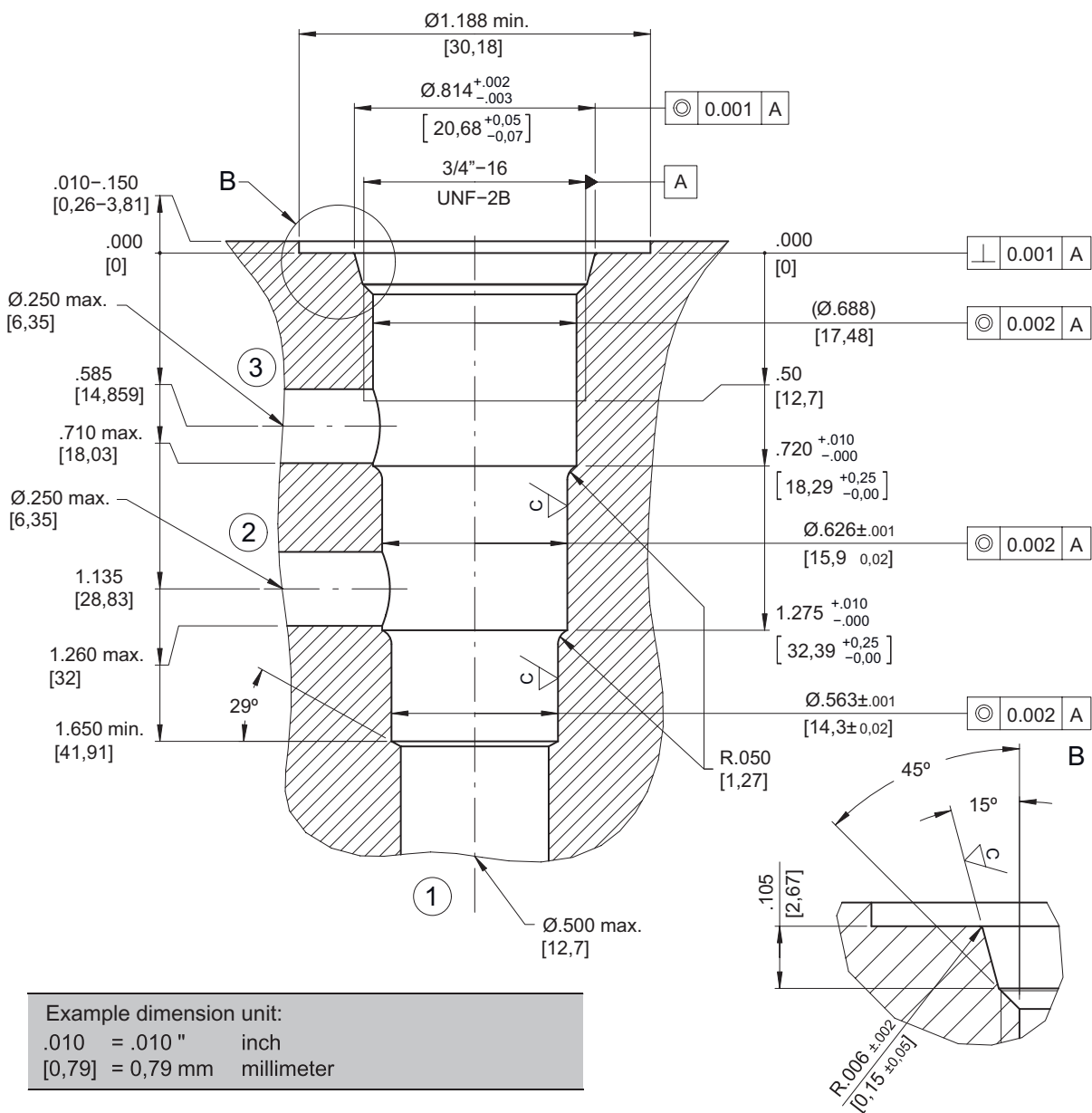

Example dimension unit:
 .010 = .010 " inch
 [0,79] = 0,79 mm millimeter

Dimension Tolerances	
Unless otherwise specified	
0.000	± .005"
0.00	± .010"
Angles	± 1/2°

Surface roughness		
	C	D
Ra	45 µin (1.15 µm)	125 µin (3.2 µm)
	Unless otherwise specified	

Installation information



ATTENTION!

You must maintain the specified positional and diametral tolerances. To ensure trouble-free operation of the screw-in cartridges, we strongly recommend that pilot drilling, boring, reaming and cavity thread-cutting are always performed in one setup.



NOTE!

The cavity type C0830 complies with the standard according to: ISO 17209: 3/4-03-0-13 and NFPA/T3.5.50: 0.750-03-0-09.



NOTE!

We offer form tool sets for sale or hire. For further information, see data sheet 520-P-000050.