

Directional valve 2-way/2-position

$Q_{\max} = 30 \text{ l/min}$, $p_{\max} = 350 \text{ bar}$

direct acting, spool type, pneumatical or hydraulical operation

Type series: AODV-10-_-O1-...

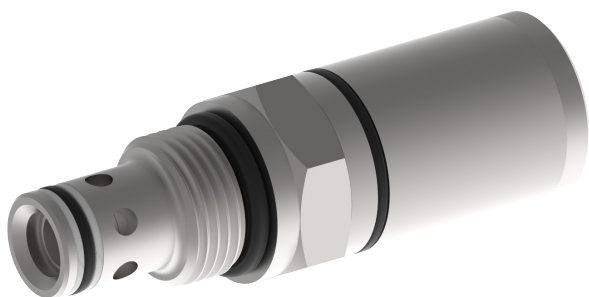

- Screw-in cartridge valve
- For cavity C1020
- All external parts zinc plated, chromited (CrVI-free)
- Installation in threaded port body type B1020
- Hardened precision fitted spool and sleeve provides reliable, long life
- The non-corrosive piston assembly allows this valve to operate by air or any type of hydraulic fluid
- Control spool is isolated from hydraulic fluid with high pressure seals

Description

This unit is a normally open, two position, screw-in cartridge style, direct acting spool type, air or hydraulic operated, spring return, hydraulic directional control valve. When pilot piston is not actuated, this valve al-

lows flow between ports 2 to 1. When pilot piston is pressurized, the spool in this valve is shifted and allows no flow between ports 2 to 1. Port 1 can be pressurized to 18.5× pilot port pressure.

Symbol

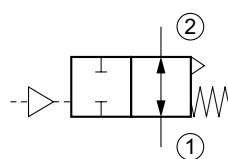

operated by air

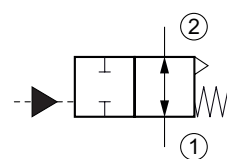

operated by hydraulic fluid

Technical data

General Characteristics	Description, value, unit
Function group	Directional valve
Function	2-way/2-position
Design	Screw-in cartridge valve
Controls	pneumatical or hydraulical operation
Characteristic	direct acting, spool type
Construction size	SAE 10 / nominal size 8
Thread size	7/8-14 UNF-2A
Mounting attitude	unrestricted
Weight	0.27 kg
Cavity acc. factory standard	For cavity C1020
Tightening torque steel	77.5 Nm
Tightening torque aluminium	50.5 Nm
Tightening torque tolerance	± 5 %
Minimum ambient temperature	- 40 °C
Maximum ambient temperature	+ 120 °C
Surface protection	All external parts zinc plated, chromited (CrVI-free)
Available seal types	several seal types available, see ordering code
Seal kit order number	NBR: SKN-1022 / FKM: SKV-1022

Hydraulic Characteristics	Description, value, unit
Maximum operating pressure	350 bar
Maximum flow rate	30 l/min
Flow direction	see symbol
Hydraulic fluid	All general purpose hydraulic fluids such as MIL-H-5606, SAE-#10, SAE-#20, etc.
Minimum fluid temperature	- 25 °C
Maximum fluid temperature	+ 80 °C
Viscosity range	10 ... 500 mm ² /s (cSt)
Recommended viscosity range	20 ... 130 mm ² /s (cSt)
Minimum fluid cleanliness (cleanliness class according to ISO 4406:1999)	class 18/16/13
Pilot piston area ratio to system pressure area	18.5:1
Internal leakage flow rate	82 cc/m at 350 bar
Pilot operating media	air or hydraulic fluid
Pilot pressure	pneumatical: 3.5 ... 17.5 bar / hydraulical: 3.5 ... 70 bar

Performance graphs

measured with oil viscosity 28.5 mm²/s (cSt)

$\Delta p = f(Q)$ Pressure drop-flow rate characteristic

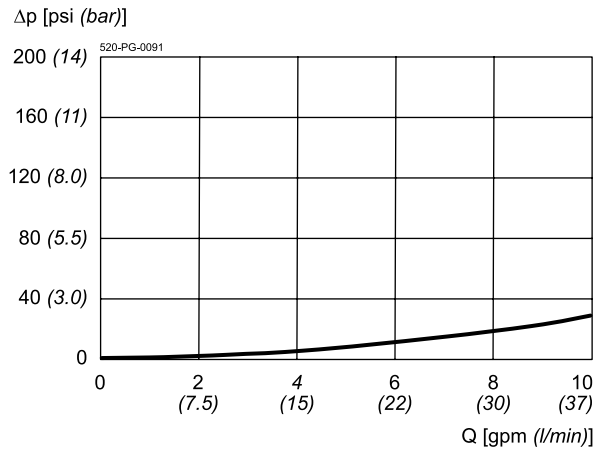

Dimensions and sectional view

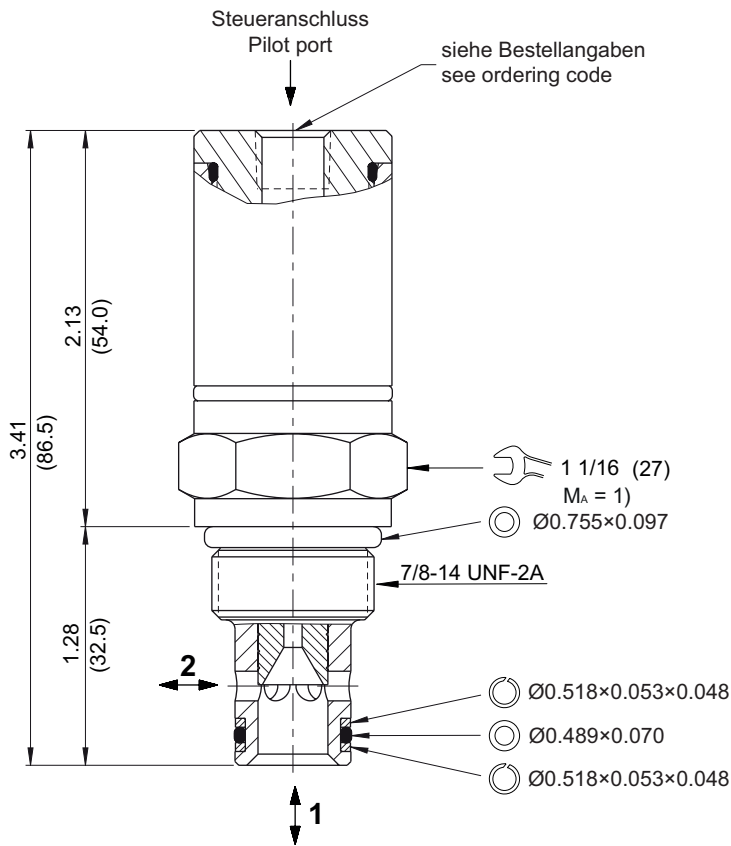

Installation information



ATTENTION!

Only qualified personnel with mechanical skills may carry out any maintenance work. Generally, the only work that should ever be undertaken is to check, and possibly replace, the seals. When changing seals, oil or grease the new seals thoroughly before fitting them.



NOTE!

1) When fitting the screw-in cartridge valve, use the specified tightening torque. The value can be found in the chapter "Technical data".



NOTE!

The seals are not available individually. The seal kit order number can be found in the chapter "Technical data".

Ordering code

e.g. AODV - 10 - N - O1 - 0 - 4T

- AODV = air or hydraulic operated directional control valve
- 10 = nominal size SAE 10 / NG 8
- N = NBR (nitril-butadien-rubber / BUNA) seals (*standard*)
- V = FKM (fluorocarbon rubber / VITON) seals
(*special seals - please consult BUCHER*)
- O1 = normally open spool (2-way/2-position)
- 0 = screw-in cartridge only
- 06TA = line-mounting body aluminum SAE #06 ports
- 06TS = line-mounting body steel SAE #06 ports
- 08TA = line-mounting body aluminum SAE #08 ports
- 08TS = line-mounting body steel SAE #08 ports
- 1P = pilot port 1/8" NPTF
- 1B = pilot port G 1/8" BSPP
- 4T = pilot port SAE #4

Related data sheets

Reference	Description
520-P-000050	Form tools
520-P-000120	Cavity C1020
520-P-000121	Threaded port body B1020