

General information

Cavity

Type series: ALM

Dimensions and sectional view

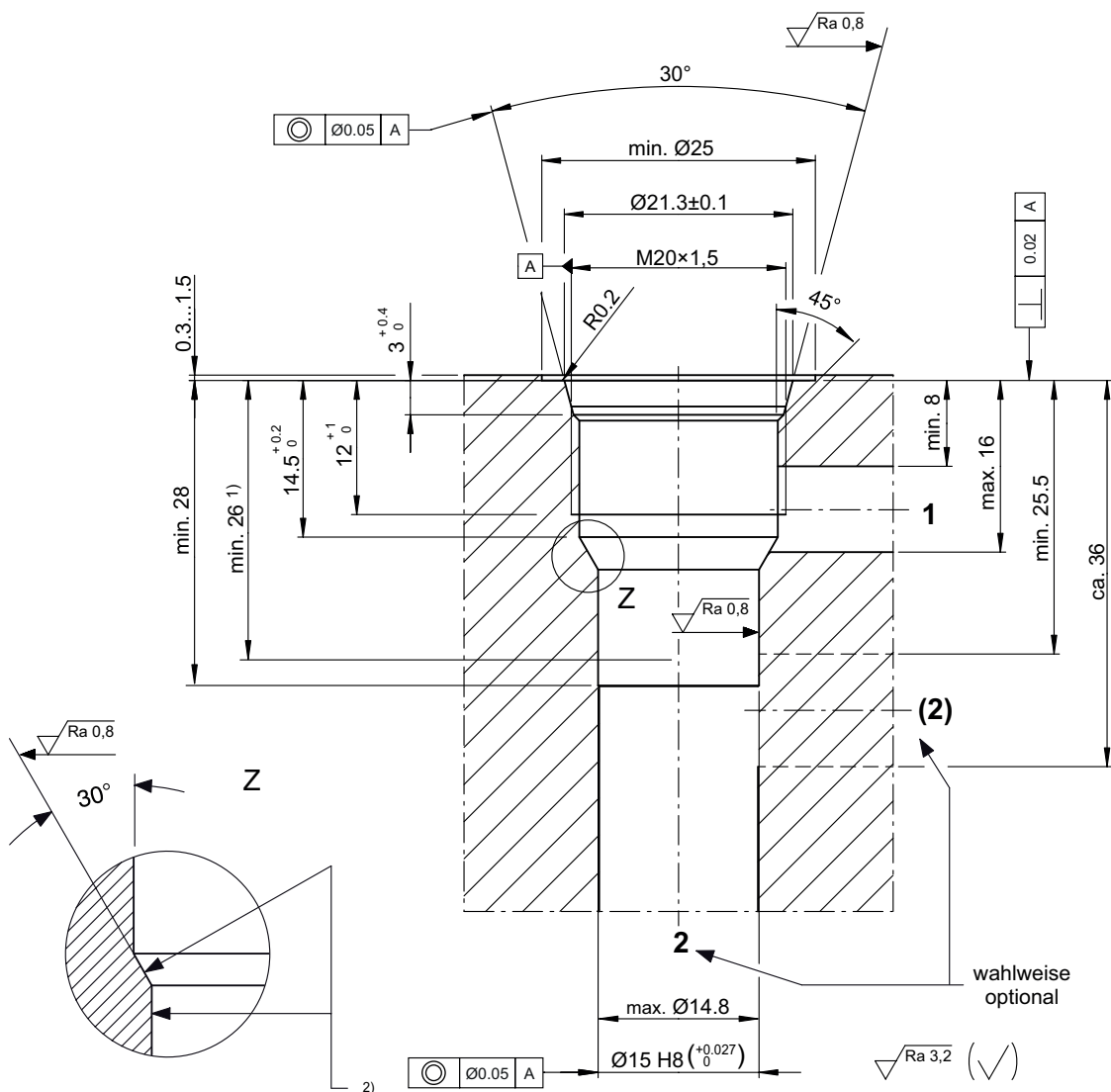

i HINWEIS!
NOTE!

- 1) Passungstiefe
Minimum depth of specified diametral tolerance
- 2) Der Gewindegang darf die Ringfläche und Ø15 H8 nicht verletzen.
The thread runout must not damage the ring surface or the Ø15 H8.

Beispiel für die Masseinheit:
Example for the dimensional units:
0.79 = 0.79 mm millimeter

Installation information



ATTENTION!

You must maintain the specified positional and diametral tolerances. To ensure trouble-free operation of the screw-in cartridges, we strongly recommend that pilot drilling, boring, reaming and cavity thread-cutting are always performed in one setup.



NOTE!

Cavity type to factory standard.



NOTE!

We offer form tool sets for sale or hire. For further information, see data sheet 400-P-040011.